



OPERATING EN INSTALLATION MANUAL

IVET-D 16A / 3,5 kVA IVET-D 30A / 7,5 kVA IVET-D 16A / 3,5 kVA - MT

Isolation transformer with soft start



MASTERVOLT
Snijdersbergweg 93, 1105 AN Amsterdam
The Netherlands
Tel.: +31-20-3422100
Fax.: +31-20-6971006
www.mastervolt.com

CONTENTS:

V2 march 03

1	GENERAL INFORMATION	3
1.1	Use of this manual	3
1.2	Guarantee Specifications.....	3
1.3	Quality.....	3
1.4	Validity of this manual.....	3
1.5	Liability.....	3
2	SAFETY GUIDELINES & MEASURES.....	4
2.1	Warnings and symbols	4
2.2	Use for intended purpose	4
2.3	Organizational measures.....	4
2.4	Warning for special dangers	4
3	INSTALLATION.....	5
3.1	Environment.....	5
3.2	Mounting	5
3.3	Connection.....	5
3.4	Adjustment of the output voltage (multi tap / model 86060351 only)	6
3.5	Adjustment of the input voltage (multi tap / model 86060351 only)	6
3.6	Commissioning the IVET-D	7
4	OPERATION.....	8
4.1	Introduction	8
4.2	Automatic circuit breaker	8
4.3	Temperature protection	8
5	DIMENSIONS	9
6	PRINCIPLE SCHEMATIC	10
7	TECHNICAL DATA	10
8	CE DECLARATION OF CONFORMITY	11

1 GENERAL INFORMATION

With the installation of electrical systems on board of a ship, extra attention must be paid to not only the safety of these systems, but to the prevention of galvanic corrosion or electrolysis of the ship hull as well. The Mastervolt IVET-D isolation transformer provides you a galvanic separation between shore-power and the onboard electrical system, eliminating these risks.

The input circuit of the IVET-D is equipped with a soft-start unit to eliminate high inrush currents, and an automatic circuit breaker to protect your electrical system against overload.

1.1 Use of this manual

- This manual serves as a guideline for safe and effective operation, installation, maintenance and possible correction of minor malfunctions of the IVET-D.
- It is therefore obligatory that every person who works with the IVET-D must be completely familiar with the contents of this manual, and that you carefully follow the instructions contained herein. The manual must be immediately accessible to the user. This manual has 8 chapters.

1.2 Guarantee Specifications

Mastervolt guarantees that this unit has been built in accordance with the legally applicable standards and specifications. Should work take place, which is not in accordance with the guidelines, instructions and specifications contained in the user manual, damage may occur and / or the unit may not fulfil its specifications. All of these matters may mean that the guarantee may become invalid.

1.3 Quality

During the production and prior to their delivery, all our units are exhaustively tested and inspected. The guarantee period is two years.

1.4 Validity of this manual

All of the specifications, provisions and instructions contained in this manual apply solely to the MASTERVOLT-delivered standard versions of the IVET-D.

1.5 Liability

MASTERVOLT can accept no liability for:

- Consequential damage due to use of the IVET-D.
- Possible errors in the manuals and the results thereof.



CAREFUL!

Never remove the type and number plate.

Important technical information required for service, maintenance & secondary delivery of parts could be found from the type number-plate.

2 SAFETY GUIDELINES & MEASURES

2.1 Warnings and symbols

Safety instructions and warnings are marked in this manual by the following symbols and pictograms:



Procedures which deserve extra attention.



CAREFUL!

Special data: restrictions and rules with regard to the prevention of damage.



WARNING!

A WARNING refers to possible injury to the user or significant material damage to the IVET-D if the user does not (carefully) follow the procedures.

2.2 Use for intended purpose

1 The IVET-D is constructed as per the applicable low voltage directive and safety regulation EN 60950

2 Use the IVET-D only:

- In a technically correct condition.
- In a closed room, protected against rain, moisture, dust and non-condensing circumstances.
- Observing the instructions in the manual.



WARNING!

Never use the IVET-D at locations where there is danger of gas or dust explosion!

3 Use other than as mentioned under 2 is not considered to be consistent with the intended purpose. MASTERVOLT is not liable for any damage resulting from the above.

2.3 Organizational measures

The user must always:

- Have access to the user manual
- Be familiar with the contents of this manual. This applies particularly to Chapter 2, Safety Guidelines & Measures.

2.4 Warning for special dangers

1 Check the wiring at least once a year. Defects such as loose connections, burnt wiring etc. must be corrected immediately.

2 Do not work on the IVET-D or the system if it is still connected to a power source. Only allow changes in your electrical system to be carried out by qualified electricians.

3 Installation must be done in accordance with the local regulation for electrical installations.

4 For a safe installation the right cable diameter must be applied.

5 Isolation transformers are heavy! Ensure adequate mounting security and always use suitable handling equipment for transportation.

3 INSTALLATION

3.1 Environment



WARNING

The electrical system must be disconnected from any power source during installation!

Ensure that the IVET-D is placed in a dry, well ventilated environment, protected against water and/or dust.

The airflow may not be blocked. For optimum airflow, the IVET-D should always be mounted vertically.

The EMC-characteristics to which the IVET-C is part of, is affected by the way the wiring is installed.

3.2 Mounting

Be sure that the panel to which the IVET-D is mounted is strong enough to last the weight of the IVET-D. Use M6 or M8 bolts to fix the IVET-D to the mounting panel.

Take the following steps to mount the cabinet:

1. Determine the spots to fix the bolts into the mounting panel, using the outline drawings of chapter 5 (page 9)
2. Screw the topmost bolts somewhat into the mounting panel.
3. Place the IVET-D with its key holes over the two bolts. Tighten the bolts finger tight, so that shifting the cabinet is still possible.
4. Place the two lowermost bolts into the mounting panel.
5. Fasten all bolts securely.

3.3 Connection



WARNING

Check the adjustments for input voltage and output voltage before operating the IVET-D.

Check from the type number plate whether:

- the AC voltage of the power source is the same as the input voltage of the IVET-D.
- the output voltage of the IVET-D is appropriate to supply the connected load.

Refer to chapter 3.4 and 3.5 to adjust the input voltage, respectively the output voltage of the “multi tap” version.

To connect the wiring, proceed as follows:

1. Unscrew the four screws of the cabinet's front panel and remove the front panel.
2. Pass the shore cable through the left hand sided cable gland, at the bottom of the cabinet. Pass the AC-output cable through the right hand sided cable gland.
3. Cut the cable at length in accordance with figure 1. Strip the three conductors for 8mm.

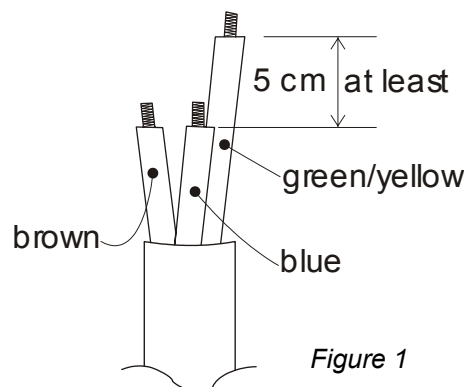

Figure 1

4. Connect the shore cable to the terminals that are indicated with “INPUT”. Connect the load to the terminals that are indicated with “OUTPUT”. Refer to figure 2. Connect the

green/yellow wire to PE, connect the brown wire to L1 and connect the blue wire to N.

5. Tighten the cable-glands securely.

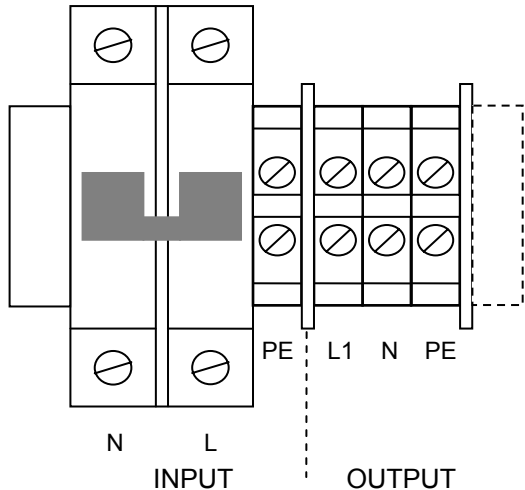

Figure 2

3.4 Adjustment of the output voltage (multi tap / model 86060351 only)

The output voltage of the IVET-D must be the same as the input voltage of the connected load. Adjust the output voltage by changing the wiring of the IVET-D according to the following instructions:

- 230 Volt: refer to figure 3. Connect transformer wire 6 to terminal 6 at the **230V-side** and connect the transformer wire 7 to terminal 7 at the **230V-side**.
- 115 Volt: refer to figure 4. Connect transformer wire 6 to terminal 6 at the **115V-side** and connect the transformer wire 7 to terminal 7 at the **115V-side**.

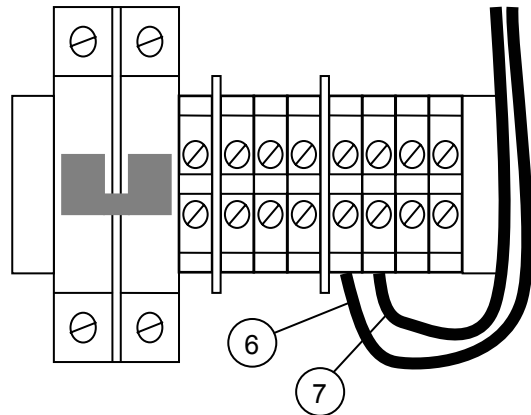

Figure 3: 230V output voltage

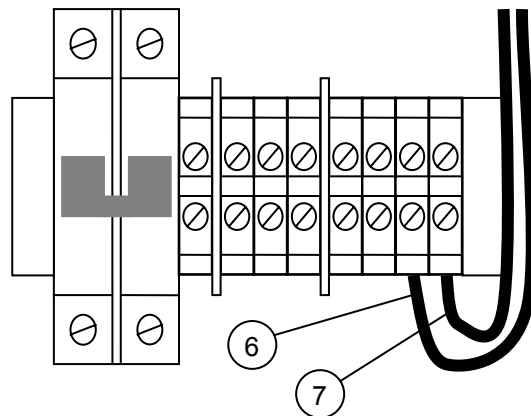

Figure 4: 115V output voltage

3.5 Adjustment of the input voltage (multi tap / model 86060351 only)

The AC voltage of the power source must be the same as the input voltage of the IVET-D. Select the input voltage by shifting the input voltage selector to the required voltage. The input voltage is indicated by the selector.



Replace the 16 Amps circuit breaker by the loose supplied 32 Amps circuit breaker if the IVET-D is connected to a 115V power source.

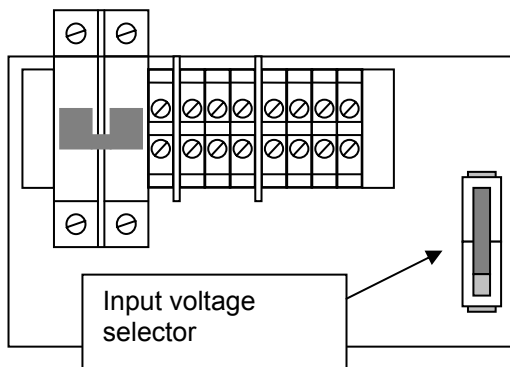



Figure 5: input voltage selection

The input of the isolation transformer is standard provided with a 16 Amps automatic circuit breaker. This circuit breaker protects the transformer against overload if the transformer is connected to a 230V power source. Replace the 16 Amps circuit breaker by the loose supplied 32 Amps circuit breaker if the IVET-D is connected to a 115V power source. Compared to 230V, the current will be twice as high at 115V if the connected load is the same.

3.6 Commissioning the IVET-D

 Double check all wiring and connections before operation.

1. Switch on the automatic circuit breaker of the IVET-D.
2. Close the cabinet by fixing the front cover with the four screws.



WARNING

The IVET-D should only be taken into operation while the front cover is closed.

3. Connect the shore cable to the power source.

4 OPERATION

4.1 Introduction

The Mastervolt IVET-D isolation transformer provides you a galvanic separation between shore-power and the onboard electrical system. The input circuit of the IVET-D is equipped with a soft-start unit to eliminate high inrush currents, and an automatic circuit breaker to protect your electrical system against overload.

The IVET-D operates automatically. Under normal circumstances, there is no need for operation.

4.2 Automatic circuit breaker

The IVET-D is provided with an internal automatic circuit breaker. This circuit breaker switches off the IVET-D in case of overload or short-circuits. To reset the internal circuit breaker, proceed as follows:

1. Disconnect the shore cable from the power supply. Be sure the IVET-D is disconnected from any power source.
2. Investigate the cause of failure of the automatic circuit breaker, like overload or short-circuits. Disconnect all loads from the IVET-D.

3. Unscrew the four screws of the cabinet's front panel and remove the front panel.
4. Switch on the circuit breaker (see figure 5)
5. Close the cabinet by fixing the front cover with the four screws



WARNING

The IVET-D should only be taken into operation while the front cover is closed.

6. Connect the shore cable to the power source.

4.3 Temperature protection

Despite its high efficiency, the IVET-D will still produce some heat, especially with high loads connected.

The heat that is produced by the transformer of the IVET-D is discharged by means of a cooling fan. This cooling fan starts automatically when the transformer's temperature exceeds 80°C. If a temperature of 120 °C is reached, the IVET-D is switched off until the temperature has dropped again below 80°C approximately.

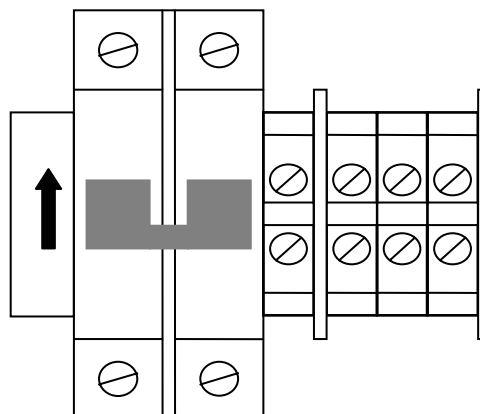
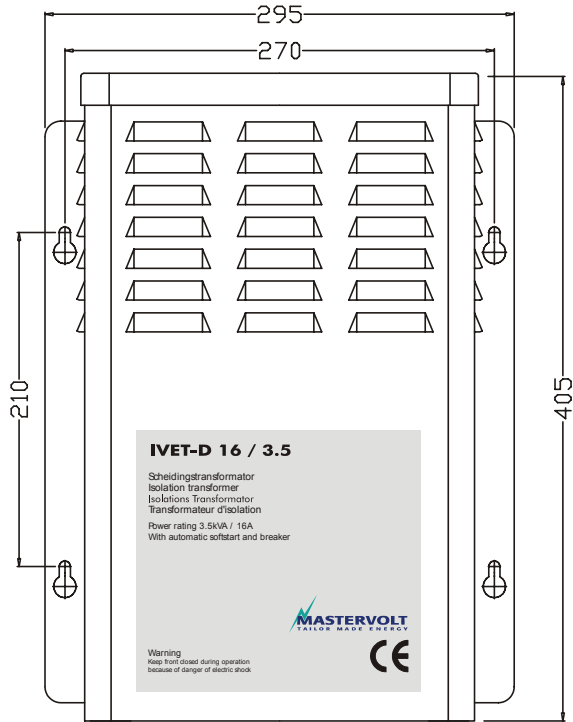
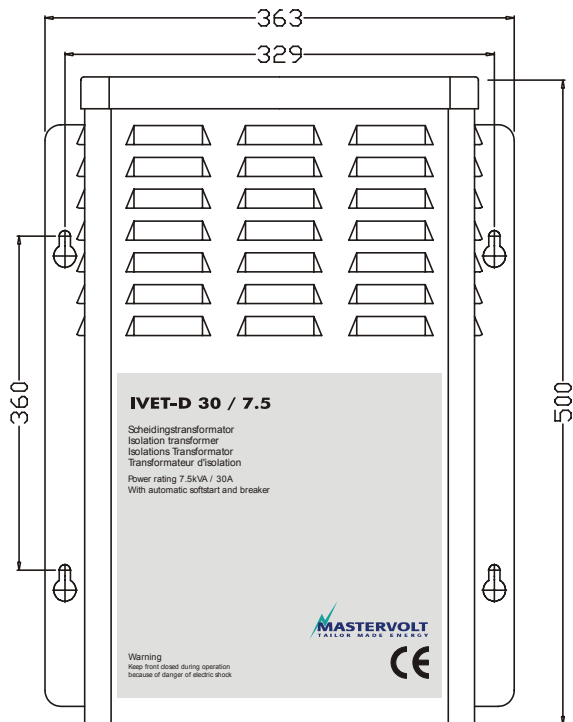
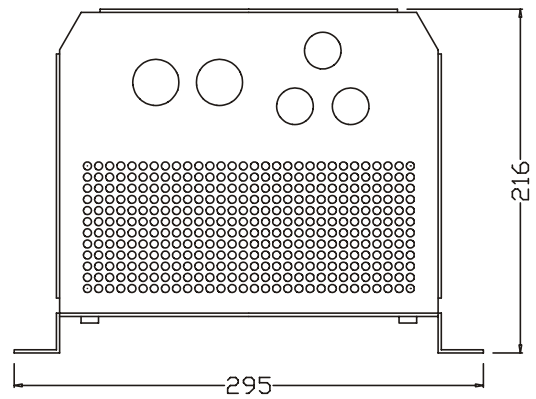

Figure 6:
Power up automatic circuit breaker

5 DIMENSIONS



IVET-D 16A 3,5kVA
 IVET-D 16A 3,5kVA-MT



IVET-D 30A 7,5kVA

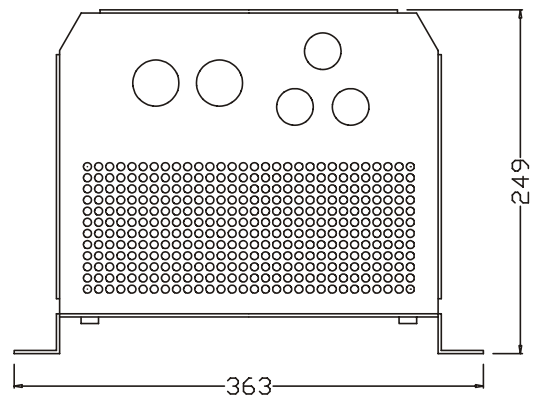

6 PRINCIPLE SCHEMATIC

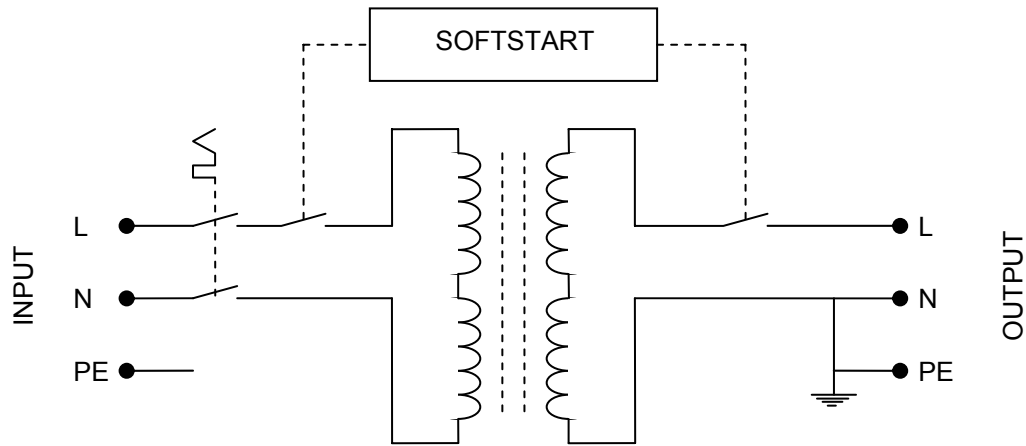

7 TECHNICAL DATA

Type	IVET-D 16A 3,5kVA	IVET-D 30A 7,5kVA	IVET-D 16A 3,5kVA - MT
Part number	86050351	86050751	86060351
ALGEMEEN			
Input voltage	220-240V	220-240V	220-240V / 110-120V
U-in adjustable	No	No	Yes
Output voltage	220-240V	220-240V	220-240V / 110-120V
U-out adjustable	No	No	Yes
Frequency in/out	50-60 Hz	50-60 Hz	50-60 Hz
Load	16 Amp. / 3680 W	30 Amp. / 6900 W	16 Amp./ 3680W @ 230V 32 Amp / 3680W @ 115V
Soft start	Yes	Yes	Yes
Transformer	Torodial		
Cooling	Natural convection, above 80°C forced cooling		
Temp. Protection	Load is disconnected at temperatures above 120°C		
CABINET			
Model	D1	D2	D1
Dimensions (hxwx d)	407 x 295 x 220 mm	505 x 305 x 250 mm	407 x 295 x 220 mm
Protection degree	IP 23	IP 23	IP 23
Colour	RAL 7035 (grey/white)	RAL 7035 (grey/white)	RAL 7035 (grey/white)
Weight	23 kg	48 kg	23 kg

8 CE DECLARATION OF CONFORMITY

Manufacturer: Mastervolt

Address: Snijdersbergweg 93
1105 AN Amsterdam
The Netherlands

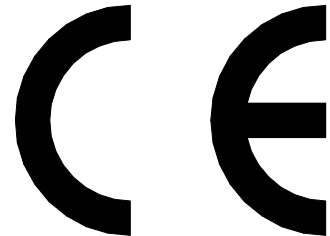

Herewith declares that:

Product: IVET-D 16A / 3,5 kVA
IVET-D 30A / 7,5 kVA
IVET-D 16A/ 3,5 kVA - MT

Is in conformity with the provision of the EEC directive EMC 89/336/EEG and amendments 92/31/EEG and 93/68/EEG.

The following harmonized standards have been applied:

Emission: EN 50081-1:1992
Immunity: EN 50082-1:1992
Safety: EN 60950-1:1992

Amsterdam,

A handwritten signature in black ink, appearing to be 'Dr. F.J. ter Heide', written over a large, light-colored scribble or stamp.

Dr. F.J. ter Heide,
Director MASTERVOLT



Snijdersbergweg 93, 1105 AN Amsterdam, The Netherlands
Tel: + 31-20-3422100 Fax: + 31-20-6971006 Email: info@mastervolt.com