



INSTALLATION MANUAL

WHISPER 6 / 8 / 12 6 ULTRA

-3000 / 1500 RPM-

Marine diesel generating set 230V-50Hz

Digital Diesel Control



Art.nr. 50200361

MASTERVOLT
Snijdersbergweg 93
1105 AN Amsterdam
The Netherlands
Tel.: +31-20-3422100
Fax: +31-20-6971006
<http://www.mastervolt.com>

V2. October 2004

This manual applies to the Mastervolt Whisper 6/8/12 and 6 ULTRA Marine Diesel Generating set controlled by Digital Diesel Control first launched in April 2004. For earlier models refer to other manuals available on our website: www.mastervolt.com

CONTENTS

1	INSTALLATION	3
1.1	Location	3
1.2	Instructions for optimal sound and vibration insulation	3
1.2.1	Steel base plate	3
1.2.2	Further recommendations	3
1.3	Ventilation	3
1.4	Connections	4
1.4.1	Fuel supply	4
1.4.2	Cooling	7
1.4.3	Exhaust system	9
1.4.4	Digital Diesel Control system 12 Volt	12
1.4.5	AC power system 230 Volt (120 Volt)	13
2	INSTALLATION SPECIFICATIONS	15
2.1	Installation table	15
2.2	Commission table	16
2.3	Technical data	17
2.4	Specification of the accessories	17
2.5	Installation materials	18
3	DIAGRAMS AND DRAWINGS	22
3.1.	DC wiring diagram	22
3.2.	Codes and colors	23
3.3	Wiring diagram electronic governor (optional)	24
3.4	AC wiring diagram Whisper 230V 50Hz	25
3.5	Remote panel dimensions	26
3.6	Whisper 6/8/12 and 6 ULTRA dimensions	27

1 INSTALLATION

To ensure reliability and durability of the equipment, it is very important that the installation is carried out with the utmost care and attention. To avoid problems, such as temperature problems, noise levels, vibration, etc. the instructions set out in this manual must be followed and all installation work must be carried out professionally.

1.1 LOCATION

Since Whisper generating sets have extremely compact dimensions, they can be installed in tight locations. Please consider that even almost maintenance-free machinery must still remain accessible.

When selecting the location area to mount the generating set, make sure there is sufficient room to carry out any maintenance work. The unit must be easily accessible on the service side and on the distribution side to have access to the V-belt.

Please also note that in spite of the automatic oil pressure sensor it is still essential that the oil level is checked regularly.

1.2 INSTRUCTIONS FOR OPTIMAL SOUND AND VIBRATION INSULATION

Position the generating set as low as possible in the vessel. As the generating set already has secured to the base frame by means of flexible engine mountings, the frame can be mounted directly to the vessel's main structure.

1.2.1 Steel base plate

However to keep resonant vibrations at a minimum, it is possible to mount the generating set on a solid steel base plate, approx. 20 mm (3/4") weighing approx. 60 kg or 50% of the weight of the generating set. The engine draws its inlet combustion air through several holes in the capsule base. Therefore the capsule must be fitted with sufficient clearance between the capsule underside and the base plate. For the Whisper 6/8-3000rpm a steel base plate is available with Mastervolt as an optional accessory (ref. fig. 12, page 36).

1.2.2 Further recommendations

Whisper generating sets are standard equipped with a "GRP" (Glass Reinforced Plastic) sound cover. The canopy has been designed to give an effective sound insulation. For optimum sound and vibration dampening, the

following factors should be considered.

- 1 Avoid mounting the generating set in close proximity to thin walls or floors as that may resonate.
- 2 Sound dampening is extremely poor if the generating set is mounted on a light weight flimsy surface such as plywood which will only amplify vibrations. If mounting on a thinner surface cannot be avoided, this should at least be reinforced with stiffening struts or ribbing. If possible, holes should be drilled or cut through the surface to help reduce the resonance. Covering the surrounding walls and floors with a heavy coating plus foam will certainly improve the situation.
- 3 Never connect the base of the generating set directly to bulkheads or tanks.

1.3 VENTILATION

The generating set normally draws air from the engine room. Engine rooms with natural ventilation must have vent openings of adequate size and location to enable the generating set to operate without overheating. To allow an ample supply of air within the temperature limits of the generating set an opening of at least 100 cm² is required.

A "sealed" engine compartment must have a good extraction ventilator to maintain reasonable engine room temperatures. High temperature of intake air reduces engine performance and increases engine coolant temperatures. Air temperatures above 40°C reduce the engine power by 2% for each 5°C of rise. To minimise these effects the engine room temperature must not be more than 15°C above the outside ambient air temperature.

Apply a combination of ventilators, blowers and air intake ducting to meet the temperature limit. The air inlet ducts should run to the bottom of the engine room to clear fumes from the bilge and to circulate fresh air. Air outlets should be at the top of the engine room to remove the hottest air. An engine room blower should be used as an extraction ventilator to remove air from the engine room. In cases where it is impossible to meet the above mentioned temperature limit by using machine room ventilation, connections are to be made for an air inlet directly to the enclosure. With these connection the generating set can be directly connected to an air duct.

Air inlets should be louvered, where appropriate, to protect the engine room and to protect the generating set from water spray. As an extra precaution, the fitting of a cowl ventilator with dorade box located as high as possible, is recommended.

1.4 CONNECTIONS

The generating set comes supplied with all supply lines and output cable (i.e. electric cables, cooling water connections, exhaust, fuel lines etc.) already connected to the engine and generator. The supply lines are fed through the capsule's base. The connections are marked as shown in fig. 1.

All electrical connections, cable types and sizes must comply to the appropriate national regulations. Supplied cables are rated for ambient temperatures up to 70°C. If the cables are required to meet higher temperature requirements, they must be run through conduits.

1.4.1 Fuel supply

1 FUEL TANK

Fuel tanks should be made of appropriate material such as (stainless) steel or plastic. Steel tanks should not be galvanised or painted inside. Condensation can occur in metal tanks when temperature changes. Therefore, water accumulates at the bottom of the tank and provisions should be made for the drainage of this water.

The tank will need a filling connection, a return connection and an air ventilation connection which will require protection against water entry.

Some official regulations do not allow connection points at the base of the fuel tank; in this instance connections are to be made at the top of the tank with internal tubing down to a few cm above the bottom of the tank.



ATTENTION!

Before working (installation) on the system read the section safety instructions.

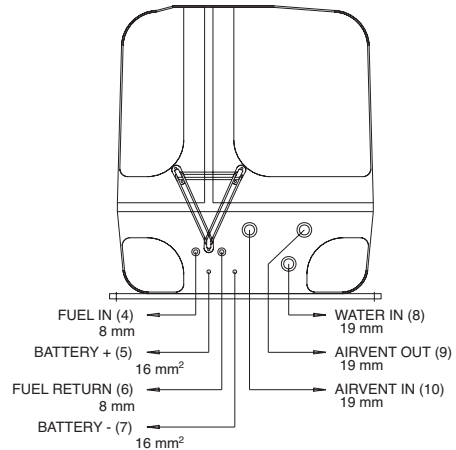
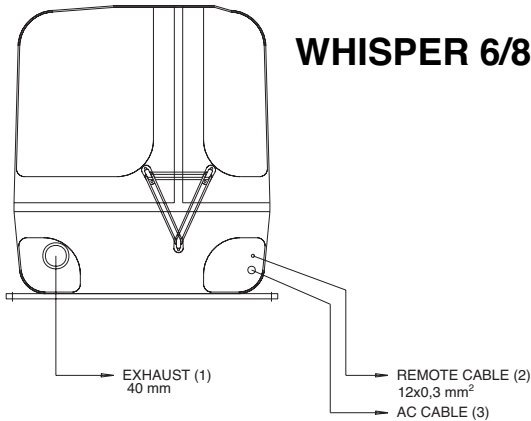

WHISPER 12/6 ULTRA

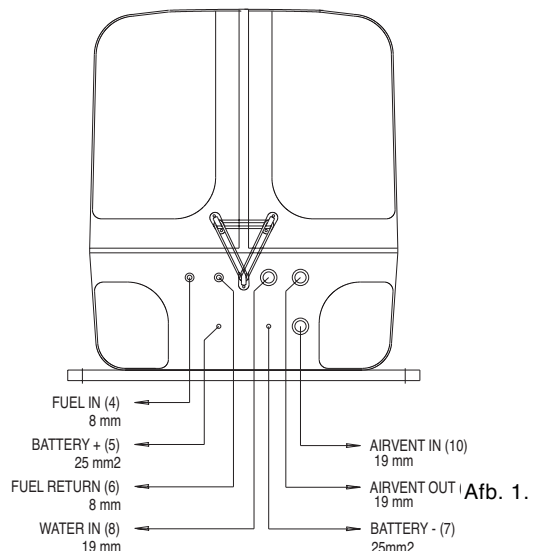
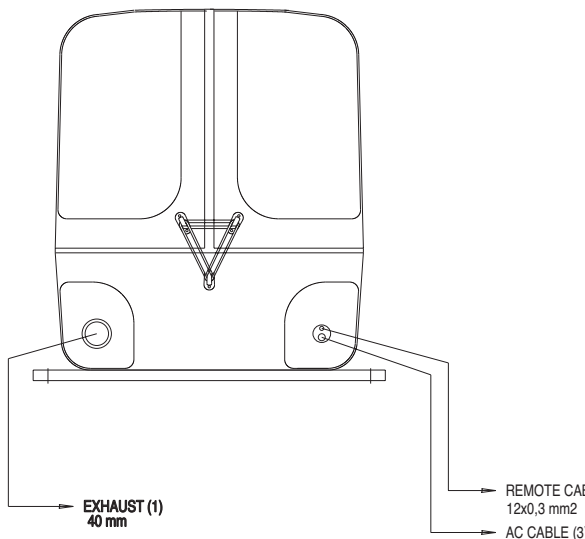

Afb. 1.

2 FUEL LIFT PUMP

The generating set itself is equipped with a fuel lift pump; therefore the tank can be installed at a lower level than the generating set. The maximum suction height is 1 m.

If the pump has to lift the fuel higher than one meter an external fuel lift pump must be installed. The control board is already prepared to connect an extra fuel pump.

3 FUEL PIPES

When the tank is above the generating set we recommend to end the return line on the top of the tank. When the return is on the top - in case of a leakage - the return line cannot overflow because of siphoning. One will only need a fuel cock in the fuel supply line.

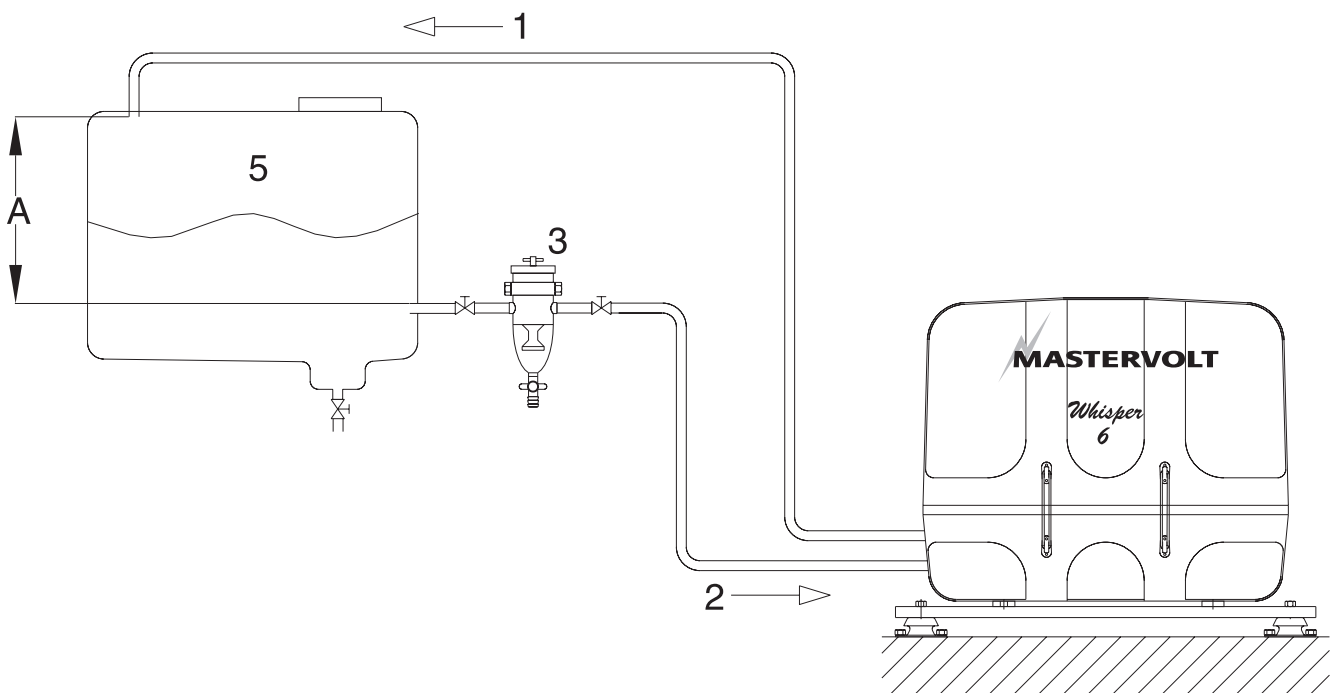

Fig. 2.

- 1 Fuel return;
- 2 Fuel supply;
- 3 Prefilter / water separator (optional);
- 5 Fuel tank;

When the tank is below the generating set we recommend to end the return line on the bottom of the tank (A) below the inlet of the supply line to discharge under the lowest fuel level. This prevents air getting into the fuel line. Here also one need only a fuel cock in the supply line.

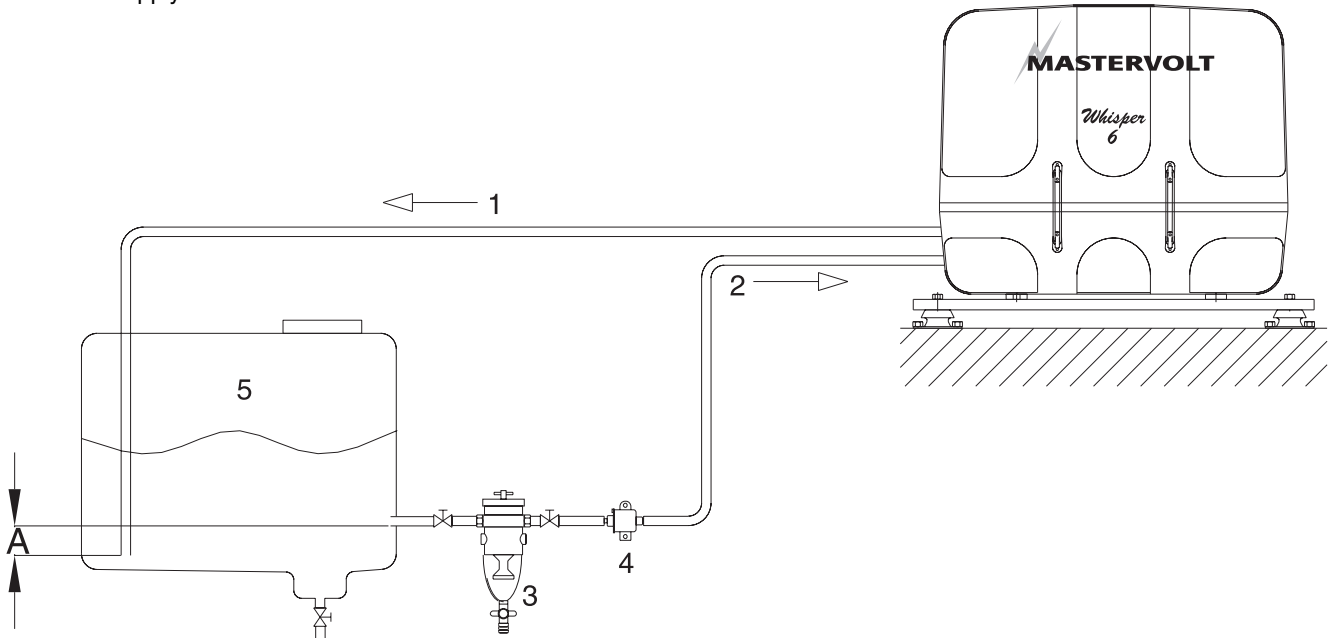

Fig. 3.

Both supply and return fuel pipe lines should be appropriate material and 8 mm outer diameter tubing. The quality of the tubing of fuel pipes could be submitted to local regulations depending on the application of the vessel.

The fuel pipes can be plumbed to the flexible hoses which are on the generating set and have a connection to fit to 8 mm pipe. This fuel lines fulfils CE standards and are according to ISO 7840 A2.

It is important to avoid bends in the pipes, as they could trap air bubbles. The return pipe should never be connected to the suction pipe. Other consumers of diesel fuel, such as the propulsion engine and heaters, have to be connected to separate suction and return pipes

- 1 Fuel return;
- 2 Fuel supply;
- 3 Prefilter / water separator (optional);
- 4 Extra fuel lift pump (optional);
- 5 Fuel tank.

4 FUEL FILTERS

A fine fuel filter is installed which requires maintenance. Mastervolt advises to install an extra fuel filter/ water fuel separator near the fuel tank.

Before starting your generating set for the first time follow the fuel system bleeding procedure in the users manual.

1.4.2 Cooling

Intercooling is based on a raw water pump, heat exchanger and water-injected exhaust. Cooling liquid in the internal cooling system is cooled in a heatexchanger by outboard water (raw water or seawater). After the raw water is warmed up in the heatexchanger it is dumped overboard by injecting it in the exhaust.

The generating set should have its own sea water (coolant water) inlet and should not be connected to any other engine systems. A properly installed cooling system is critical to keep engine temperatures within an acceptable range. Ensure that the installation complies to the following installation instructions.

1 THE INTERNAL COOLING SYSTEM

The internal cooling system should be filled with cooling liquid. (Refer to the users manual 2.5.12) When the engine becomes hot the liquid expands and the system is pressurised. After the pressure becomes to high the release valve in the filling cap on the manifold opens and the expanding liquid is pressed into the expansion tank that is in the delivery. Also the air in the system that is collected at the top of the manifold is released in this way. When the liquid cools down there will be underpressure. An other valve opens and the liquid is sucked into the manifold again. This system works only when there is enough liquid initially. This has to be checked when commissioning the generator set. By filling up the expansion tank when necessary there will always be enough liquid in the system. The hose that is in the delivery has to be connected to the connection on the side of the filling cap. This hose is made of heat resistant plastic and is not sensitive for kinks.

The hose goes through a hole that has to be drilled in the lower part of the canopy close to the place where the tank is mounted.

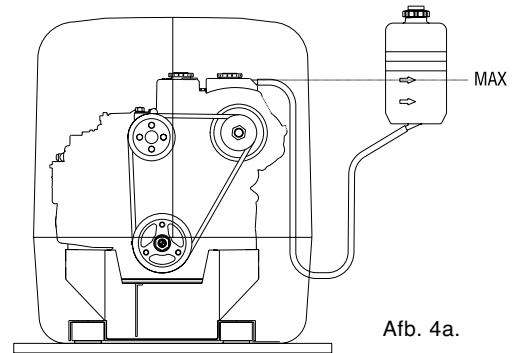

Afb. 4a.

The tank has to be placed close to the generator. When it is mounted above the top of the manifold the liquid in the tank will be drained when the cap on the manifold is taken off.

When keel cooling or radiator cooling is applied the system will not be pressurised. A cap without release valve should be applied. Refer to the special manual for these applications.

2 RAW WATER SUPPLY

For raw water supply the following installation materials are required: -a skin fitting - a sea cock - a water strainer - hoses and clamps. In order to keep the suction resistance in the line at a minimum, the sea water intake system (i.e. sea cock, tru-hull fitting, inlet filter, etc.) must have an inner diameter of at least 19 mm diameter (3/4"). The suction hose should be kept as short as possible. Raw water plumbing should avoid bends as much as possible.

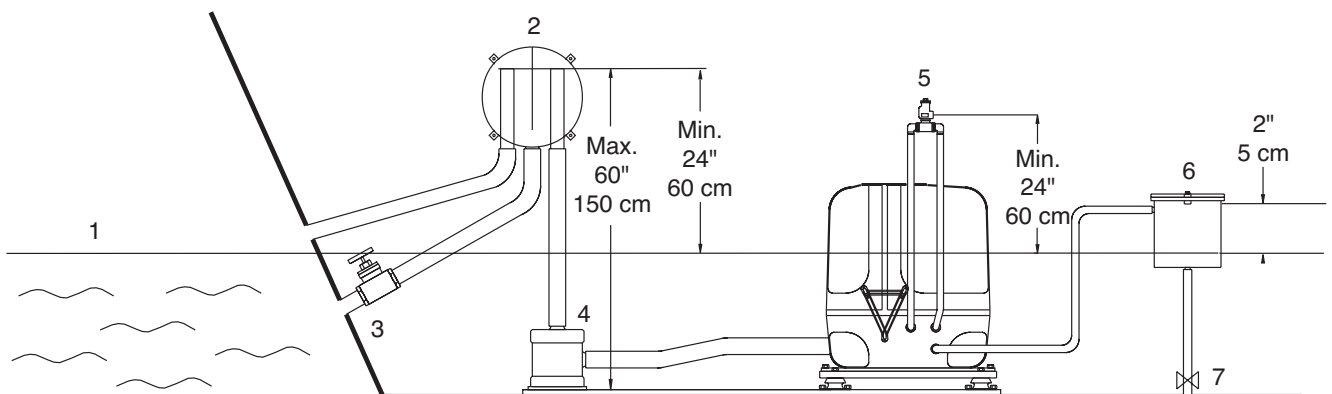

Fig. 4b.

- | | |
|----------------------------|-------------------|
| 1 Water level; | 5 Air vent; |
| 2 Water/exhaust separator; | 6 Water strainer; |
| 3 Seacock; | 7 Seacock. |
| 4 Waterlock; | |

Restriction of raw water flow, caused by kinked hoses, undersized pipes or connections, will reduce the engine cooling capability. This is the main cause for overheating of an engine.

After running the generating set for the first time, check the coolant flow rate using a stopwatch and by holding a pail of a known volume under the wet exhaust outlet. The flow rate should be according to the data in the users manual.

3 INSTALLATION OF THROUGH HULL FITTING

It is good practice for yachts to use a hull inlet fitting with an integrated strainer (water scoop). For propulsion engines in motorboats the water scoop is often mounted against the sailing direction to induce more water intake for cooling.

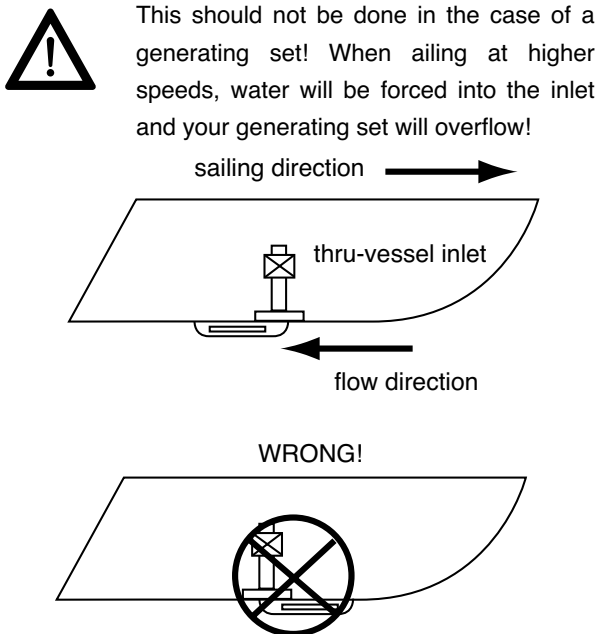

Fig. 5.

On motorboats and on sailing boats the water scoop for a generating set should be fitted with the opening faced backwards to prevent water being forced in during sailing.

4 WATER STRAINER

Use an appropriate water strainer with connections of 19 mm (3/4"). Install the water strainer in a well accessible position, (ref. to fig. 4 - 6) 15 cm above the waterline.

5 SIPHON BREAKER (AIR VENT)

When the point of water injection is below the waterline, then - when the engine is stopped - there is a risk that the cooling water may enter the engine as a result of siphoning. To avoid this happening, the generating set is designed to accommodate a siphon breaker (air vent). In the standard delivery the connections are bypassed. Hose of 19 mm (3/4") inner diameter should be used.

If the generating set cannot be mounted such that the bottom of the generating set is placed above the waterline, an air vent must be installed.

Extend the water hose of the by-pass 600 mm above waterline and install an air vent. Ideally, the air vent should be mounted above the yacht keel center line (i.e. to minimize the influence of swaying on the water intake). The hose of the drain should go downwards. Water must flow out freely; air must flow in freely as well.

Fast motorboats will lay deeper when sailing at large speed and can cause pressure on the waterinlet. This should be avoided to prevent flooding the engine.

If the air vent is clogged the water hoses will not be vented when the generating set has stopped and water can be forced into the engine. This leads to immediate engine problems and eventually severe damage!

DAMAGE CAUSED BY THE INGRESS OF WATER INTO THE ENGINE IS NEVER COVERED BY WARRANTY.

On the valve is a little hose to drain a little water that could be spilled from the valve. This hose should go down and may not end under water, because it should ventilate air into the valve to break the siphoning.

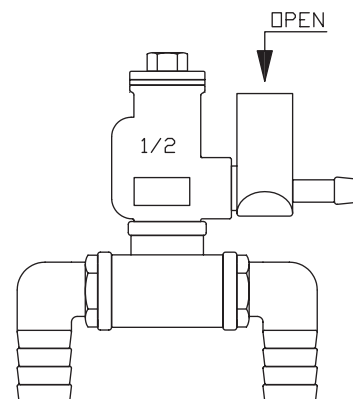

Fig. 6.

Check the air vent at regular intervals. Open, clean and lubricate the valve as required.

1.4.3 Exhaust system

Water is injected in the exhaust system of the generating set. In this way the cooling water that has passed the heat exchanger is mixed with the exhaust gases. Temperature and volume of the gases are thereby reduced considerably, so that a rubber exhaust hose can be used and the level of noise is reduced as well.

1 STANDARD EXHAUST SYSTEM INSTALLATION

The generating set exhaust system must remain completely independent and separate from the exhaust system of any other engine on board. A water lock prevents the generating set from being flooded by outside sea water and should be installed as close to the generating set as possible. The lock must be large enough to hold the entire water volume held in the hose from the top of the goose neck to the water lock. The water lock must be installed at the lowest point of the exhaust system (ref. to fig. 7-1). The exhaust hose must have an inner diameter of 40 mm. The exhaust system must be installed so that the back pressure inside the exhaust does not exceed 0.07 bar (1 psi = 70 cm watercolumn) and total length from generator to the top of the goose neck or water/gasseparator does not exceed 3m (10 ft.). (Refer to paragraph 5.4.3 of the users manual.

The exhaust hose descends from the capsule to the water lock. Then the hose rises via the "goose neck" to the through-hull exhaust outlet, situated minimum 50 mm above the water line (ref. to fig. 7-5). The "goose neck" must be vertical and situated preferable along the ship's keel center line. If the generating set is mounted less than 600 mm (24") above the waterline, a "goose neck" must be installed to prevent the engine from overflowing. It is recommended to install an extra muffler close to the through-hull fitting.

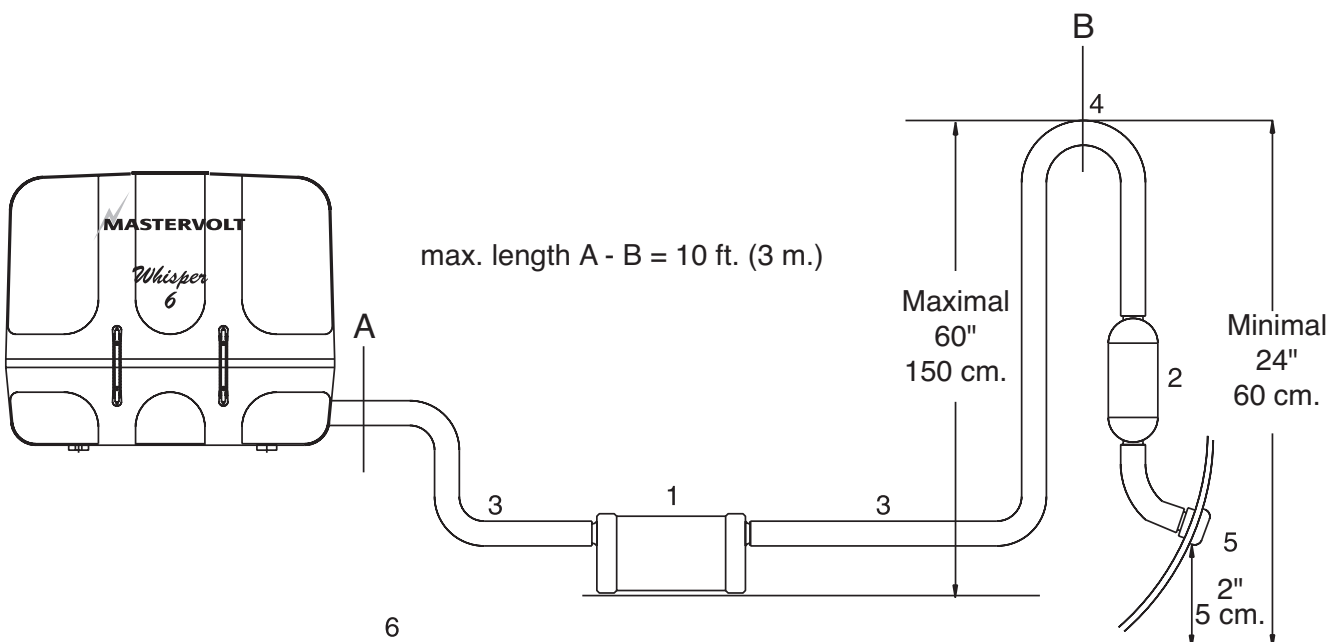

- | | |
|---------------------------|--|
| 1 Exhaust water lock; | 4 Goose neck |
| 2 Exhaust outlet muffler; | 5 Through-hull exhaust outlet Ø 40 mm; |
| 3 Exhaust line Ø 40 mm; | 6 Water level. |

Fig. 7.

2 "SUPER SILENT" EXHAUST SYSTEM

In order to reduce the noise level of the generating set to a minimum, an option to reduce the exhaust noise further (especially exhaust water splashing) is an exhaust/water separator. The exhaust/water separator allows the cooling water to be ejected through a line (A) separate from the exhaust fumes and also functions as a goose neck to prevent water from flooding the engine. If the exhaust/water separator is mounted more than 600 mm above the water level an additional goose neck is not required.

separator must then run down along the shortest possible path to the through-hull outlet. Only after the exhaust/water separator the exhaust hose may have a length of over 7,5 m if the exhaust hose diameter is also increased from 40 mm to 50 mm in order to reduce the back pressure (ref. to fig. 9). However watertraps should be avoided as the fumes still contains water and this should not accumulate in bents. (Refer to fig 8a) An additional outlet exhaust muffler close to the hull outlet will help further to reduce noise emission.

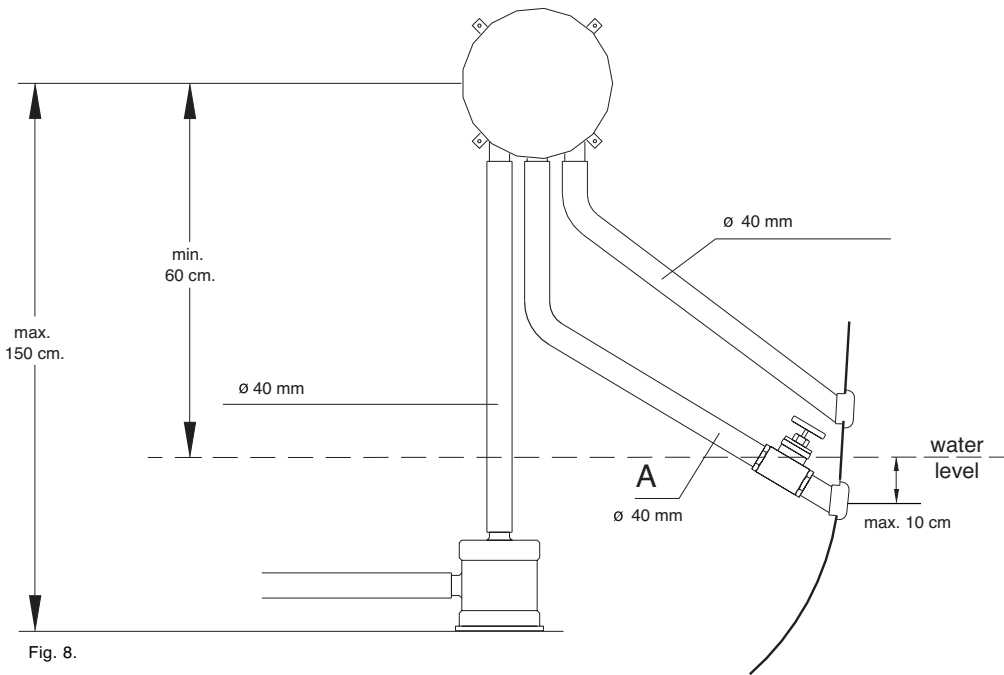

Fig. 8.

If the through-hull exhaust outlet has to be mounted far (total length exhaust piping from generator to top of goose neck (waterseparator) is more than 3 m) from the generating set, an exhaust/water separator must definitely be installed. The sea water from the

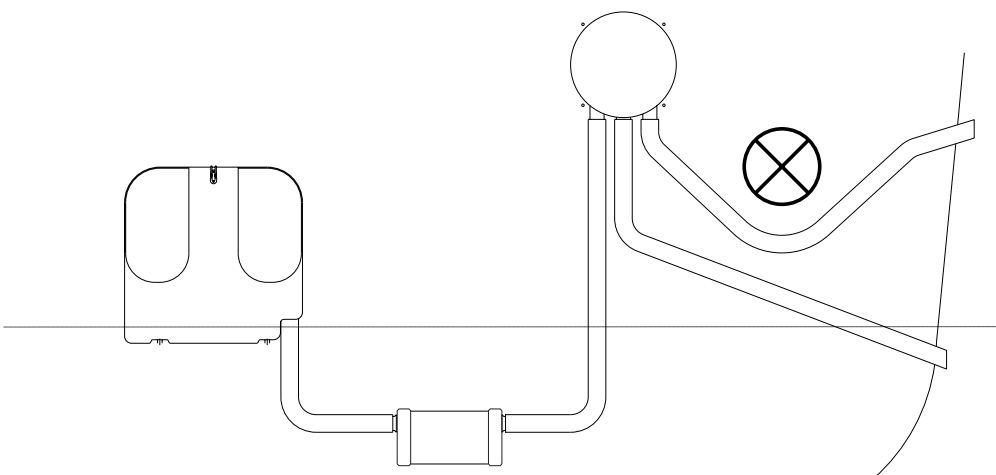

Fig. 8a.

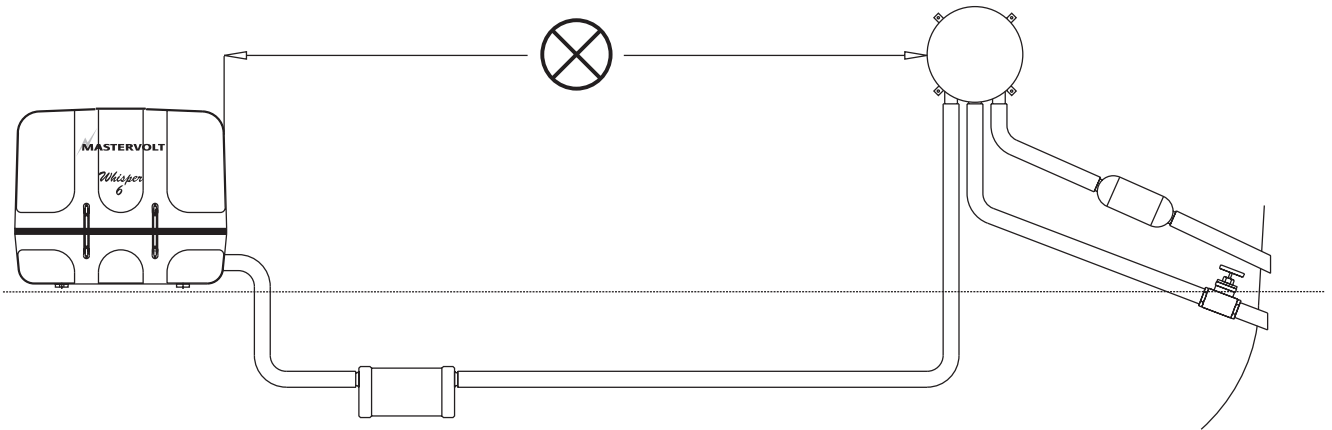
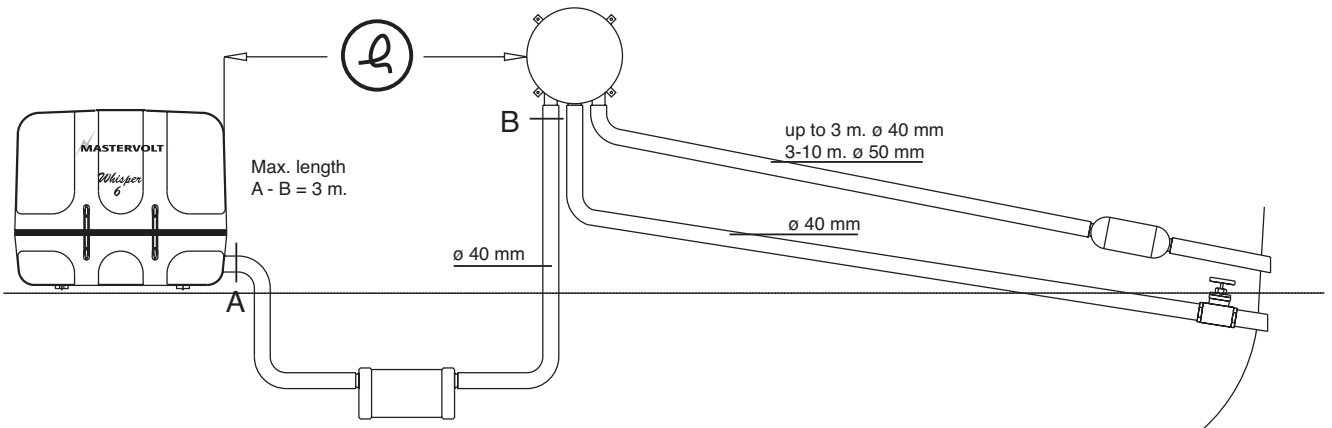

Fig. 9.



If the generating set and the exhaust system have been installed correctly, neighboring boats will not be disturbed by generating set noise. With the "super silent" exhaust system, generating set noises are almost inaudible. For optimal noise reduction, the sea water outlet from the exhaust/water separator (center outlet on the unit) should be installed below the water level to eliminate noisy splashing of the effluent sea water.

The through-hull outlet for the exhaust fumes should not direct the fumes directly toward the water surface as this will cause excessive noise (ref. to fig. 10).



Do not direct the outlet directly toward the water surface.

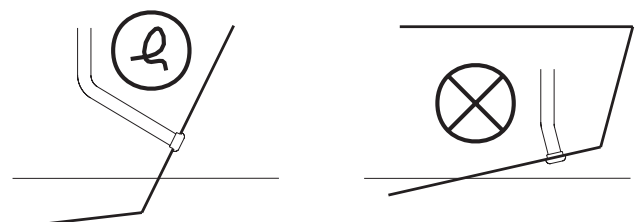

Fig. 10.

1.4.4 Digital Diesel Control system (12 Volt)

1 DIGITAL DIESEL CONTROL SYSTEM

The electrical control system is standard in 12 Volt with negative earth. Non- earth return is available as an option for aluminium vessels to prevent corrosion. All electrical wiring has been prepared on the generating set to the control panel prior to despatch from the factory. The engine is controlled by a very advanced microprocessor based system: Digital Diesel Control. The “black box” containing the microprocessor is located on top of the alternator.

A local control panel is on the generating set.

Remote control

A remote control panel also containing a microprocessor is in the delivery. A 15 m intermediate 8-pole communication cable is in the standard supply too. If necessary an optional longer (max 30 m) intermediate cable can be connected if the standard length does not suit the required distance. When a longer distance than 30 m is required, consult the Mastervolt service department for advice. Refer to fig. 11.

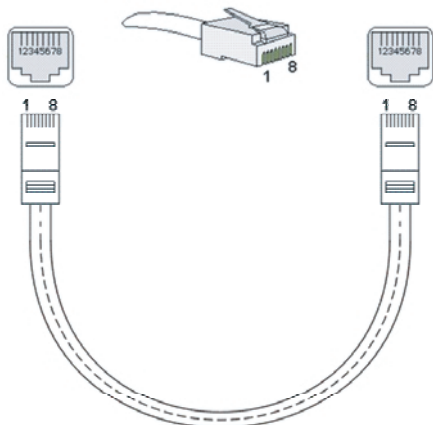

Fig. 11.

One can mount the control panel after drilling a hole in the dashboard using the plastic cover. Refer to the dimensional drawing in paragraph 3.5. The panel without the plastic cover fits the Mastervision modular panel system.

More remote control panels (slave panels) can be put in parallel by using the modular connectors on the back of the units. As a slave one can use the same panel offering all functions again. It is also possible to use an old or new type slave panel only to start and stop the generator.

Old type remote panels and system panels can be connected by means of the green connector.

Pay attention to the colour codes as indicated in fig. 12 when fitting cable to the green connector. Some software versions in old system panels (supplied before may 2004) could conflict with the software in the DDC and an up-date of the software of the system panel could be necessary. When this is the case consult to the Mastervolt service department for advice.

When using the factory settings, installation is very simple: just plug the remote cable into the remote and the generator is ready to use. Refer to fig. 12.

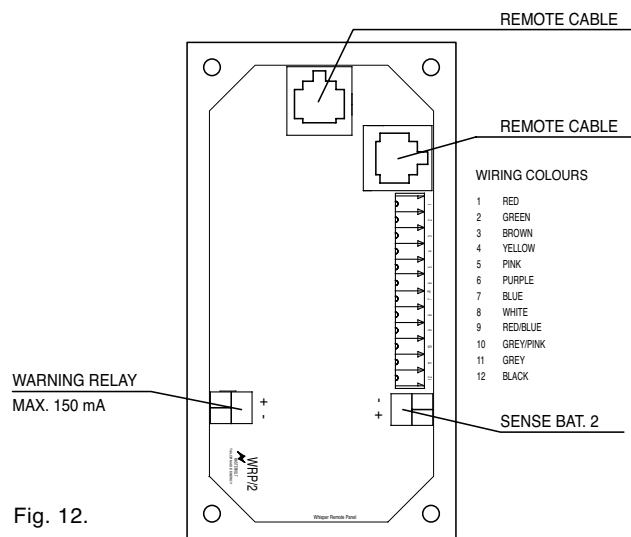

Fig. 12.

Acoustic alarm or warning lamp

One can connect an external max.150 mAmp relay to generate an acoustic warning or applying a warning lamp etc. Be aware of polarity as some relays has a diode inside and should be connected plus to plus en minus to minus as indicated. Refer to fig. 12.

Automatic start/stop

Mastervolt cannot be held responsible for damage caused by the unattended running generator using the auto-start/stop mode or interval mode.

Using the auto-start/stop (interval) mode the generator can start unexpectedly. When working on the electrical system, the 3 Amp fuse must be removed from the control panel and the battery plus cable must be removed from the battery.

The Mastervolt Digital Diesel Control system offers several options for automatic starting and stopping.

Access to this menu and other menus could be blocked. For blocking and setting up this options refer to the APPENDIX of the DDC users manual.

One of these options is to monitor a second battery (Not being the starter battery) to start the generator automatically when the voltage of this battery drops below a certain setting.

Other names for this second battery are “auxiliary battery”, “service battery”, “users battery” or “consumers battery”. We will refer to this battery as “the second battery”(BAT2). In some menus the starter battery could be indicated as “the first battery” (BAT1).

A sense wire to monitor the second battery should be connected (Attention polarity!) to the connector on the back of the remote panel. Refer to fig. 12. The sense wires must be connected directly on the second battery before a main switch and be protected by a 3 Amps fuse.

(Monitoring the generator starter battery does not require an extra sense connection)

Settings

When one want to apply other settings than the factory settings refer to the DDC users manual, especially to the APPENDIX.

2 STARTER BATTERY

For starting, the Whisper requires a battery with a capacity of at least 85 Ah. The generating set can be connected with the main engine battery or with its own battery.

We strongly recommend to use a separate battery for the generating set and to keep the wiring system for the propulsion engine and the domestic DC supply system completely separate and individually connec-

ted to separate batteries.

However the negative of all the batteries on the vessel should be interconnected (when on earth) to avoid difference in the voltage level of the earth on different places causing trouble to electronic devices which might be in the system.

The above recommendation is not valid for ships having the starter battery of the propulsion engine or other auxiliary equipment positive grounded. When this is the case an expert should be consulted.

A battery switch may be used to interrupt the positive connection.

The starter battery is charged by the alternator on the engine. An additional battery charger will help to keep the battery in good condition when the generating set in not used. A battery charger in not included in the standard supply. A high efficiency battery charging unit can be ordered from Mastervolt which is able to charge both the ship's main battery and the starter battery. Also a small charger can be used for the starter battery only, such s IVO SMART 12/10.

3 OTHER RECOMMENDATIONS AND WARNINGS

The battery should be secured for seagoing conditions and the terminals should be insulated. For extra safety the battery can be enclosed in a wooden, plastic, Fiberglas etc. (non metal) box. Even when the earth return system is applied a negative battery cable should be used and the vessel should not to be used as a conductor.

The battery cables are supplied in a standard length of 1.5 m, if longer cables are required a larger cross sectional area should be considered to compensate for voltage reduction.

When two batteries are used in series to provide a 24

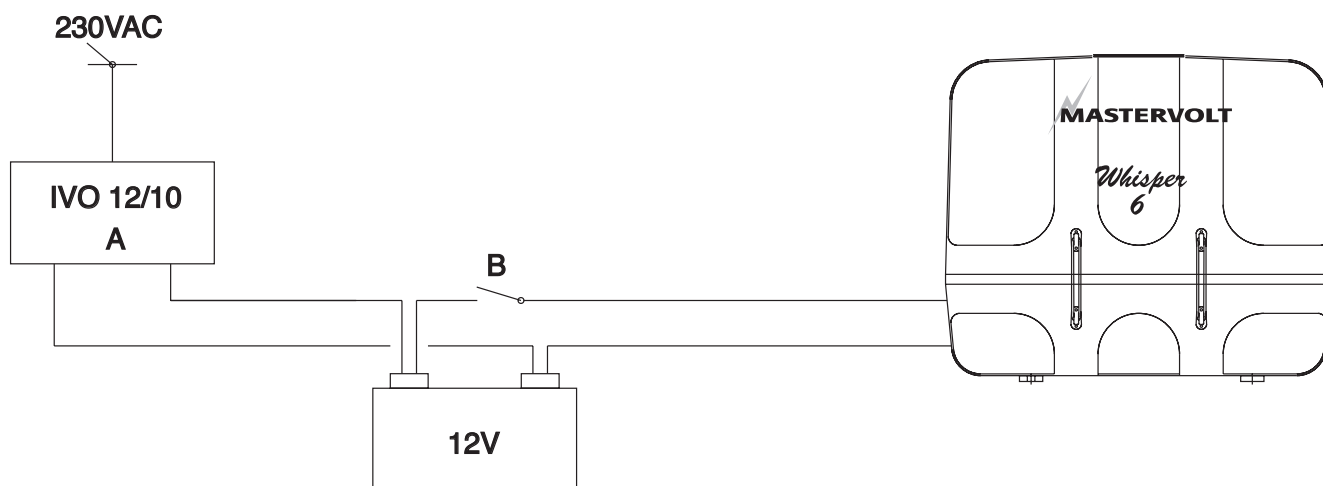

Fig. 11.

Volt supply system, never take off 12 Volt (starting) power from one of these batteries. This will result in severe damage to the batteries within short time.

Disconnect the battery leads if electrical welding is to be carried out, otherwise damage will be caused to the diodes of the alternator.



As explosive hydrogen gases are discharged during charging, the battery should be located in a well ventilated room. Ensure that the supplied battery cable connectors are properly fitted and never remove during or shortly after charging as sparking can occur, which may ignite the hydrogen gasses.

1.4.5 AC power system (230/ Volt)



Before working (installation) on the system read the sections on safety in the users manual.

Be sure that all electrical installations (including all safety systems) comply with all required regulations of the local authorities. All electrical safety/shutdown and circuit breaking system have to be installed onboard as the generating set itself cannot be equipped with such equipment for every possible variation.

The vessel's power supply system should be suitable and safe for the AC voltage which is applied and the power that will be generated. Special attention has to be paid on dividing the system in branches which are fused individually.

It is absolutely essential that each and every circuit in the on-board electrical system is properly installed by a qualified electrician.

1 FUSE

An input fuse (from the generating set to the system) should be installed to protect the installed electrical system.

For the Whispers the maximum single phase current at 230V is 25A (6), 32A (8) or 48A(12).

The fuses must be of the slow reacting type. For electrical motors connected to the system, a motor protection switch must be installed.

2 GROUNDING

The AC alternator windings are not grounded.

The housing of the alternator and all other metal parts are grounded.

To make a connection between "neutral" and "ground" could be necessary as part of a specific insulation failure protection system.

Small pleasure craft in Europe is submitted to The Recreational Craft Directive 94/25/EC. The guidelines of this directive refer to (ISO 13297).

When the installation comply to this standard the "neutral" and "ground" should be connected on the generating set by connecting the blue (neutral) wire with the terminal on which the yellow/green wire is connected.

Warnings:



In all situations the transfer switches between shore, inverter and generator should switch both neutral and L1. Of course this is the case when using a Mastervolt Masterswitch.

Be aware that insulation protection systems can be different for different applications and even within the ship there could be different standards for different spaces. We did refer to the Recreational Craft Directive that applies to pleasure craft up to 24 m of length. Sometimes one has to comply with other standards such as the rules of certification societies like Lloyds Register of Shipping or Veritas, regulations for the protection of personal, building legislation, etc. It is of the greatest importance to have expert advice on this issue.

For safety reasons connect the main ships ground to negative point of the generating set start battery. When a ungrounded DC system or positive grounded DC system is applied the battery negative should not be connected to then main ships ground.

3 CABLE

For the power cable we recommend the use of 3 wire oil resistant cable with a sufficient cross sectional area. One wire for earth is included. For very long cables it is recommended to apply cables with a larger cross section than the above mentioned.

4 TRANSFER SWITCH

A power source selector switch much be installed between the generating set and the ship's electrical supply system. This switch must ensure that all AC consumers can be switched off at once. This switch

should also be installed to keep the generating set and shore (grid) power systems separate.

Transfer switches - to switch over from shore to ship or from generating set to inverter - should be well designed to switch over all wires including neutral (and not only phases or line) and there should be provisions with the aid of timers to prevent relays from clattering.

Mastervolt advises to install a MASTERSWITCH as a power source selector. This works automatically when the generating set is not running the input remains in the shore position and as soon as the generating set is running the masterswitch switches automatically after 10 seconds delay time over to the generating set position.

2 INSTALLATION SPECIFICATIONS

2.1 WHISPER 6/8/12/6 ULTRA INSTALLATION TABLE

- 1 Install a steel foundation plate between ship's hull and generating set, with 4 shock mounts (ref. to fig. 12) 'foundation plate'(optional for Whisper 6 / 8).
- 2 Mount the generating set directly to the foundation plate.
- 3 Connect the (sea) water inlet to the strainer.
- 4 Connect exhaust system.
- 5 Connect a siphon breaker or 'air vent' into cooling circuit, if necessary.
- 6 Connect 'fuel supply line' to the water separator/ fuel filter.
- 7 Connect 'fuel return line' to the fuel tank.
- 8 Connect remote panel (just plug in).
- 9 Connect the AC cable from the AC box to the power source selector or masterswitch.
- 10 Connect plus and minus from the 12V starter battery to the battery cables.
- 11 Install a Mastervolt battery charger (optional).

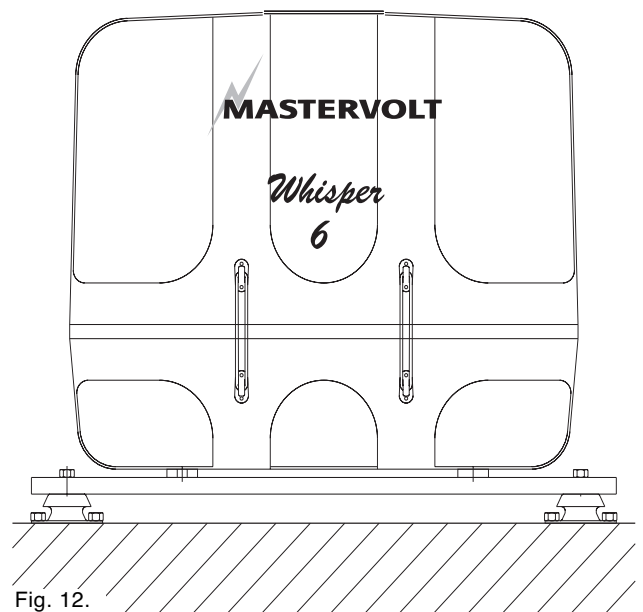

Fig. 12.

2.2 COMMISSION TABLE

- 1 Check if a siphon breaker (air vent) is necessary and has been installed.
- 2 Open the seawater inlet valve and check all water connections. Check if the strainer is installed above the seawater level.
- 3 Check if the exhaust system is properly installed. Check maximum length of exhaust hose, diameter of exhaust hose, position of waterlock, maximum lift. Also check the minimum required height of 600 mm above sea level of the exhaust loop (goose neck).
- 4 Open the seawater outlet valve and check all water connections.
- 5 Check the AC cables and the grounding.
- 6 Check if an AC breaker is installed before or after the power source selector. When there is only a circuit breaker, use it to disconnect the generating set from the grid.
- 7 Check all DC connections, check if the battery switch/circuit breaker is closed.
- 8 Open the fuel valve to bleed the fuel system. Check if there are no air leaks in the fuel supply line, and check if the lift of the fuel is less than 1 meter. Check if there is no air in the water fuel separator.
- 9 Check if the air intake in the canopy is not blocked.
- 10 Check the oil level and color of the oil.
Check the coolant level.
- 11 To bleed the fuel system push the start button on the local control (not on the remote) and hold at least 5 seconds and as long as necessary to bleed the system.
- 12 Preheat the engine by pushing the glow button for ten seconds. Start the engine by pushing the start button until the set is running. Do not push the start button longer than 5-10 seconds.
- 13 Check when the generating set is running, the delay of 5 to 10 seconds in the power source selector transfer.
- 14 Check voltage and frequency under 'no load' conditions.
- 15 Check voltage and frequency under 'full load' conditions.
- 16 Check if the battery charger of the generating set is working (max. 14.2 Volt).
- 17 Close the sound shield and check the noise level.
- 18 Stop the generating set and check the engine again for leakages of oil, fuel or water.

Installation checklist available on our website.
Extended commission form available on our website
(www.mastervolt.com).

2.3 INSTALLATION SPECIFICATIONS WHISPER 6/8/12 - 3000 RPM; 6 ULTRA

TECHNICAL DATA

Dimensions wxdxh.	6/8: 660x495x550 mm / 12/6 ULTRA:810x525x615
Weight including sound shield	6/8:178 kg / 12:210 kg / 6 ULTRA: 225 kg
Max. operation angle	25°
Remote panel 15 m cable, indicating:	Digital Diesel Control system
Battery capacity min.	12V, 60 Ah
Fuel consumption	1.5-4 l/hr, load dependent
Lift fuel pump	electric driven 12 V DC, max. lift 1 m
Cooling	indirect cooling
Cooling pump	raw water Mastervolt self priming impeller pump, PTO driven, type M
Minimum water supply	9-15 l/min
Crank case lube oil capacity,	6/8:2.4 l. + 0.5 oil filter, total 2.9 l. ; 12/6 ULTRA:3.6l. + 0.5 oil filter. total 4.1l.
Alternator	synchronous brushless, maintenance free water cooled
Voltage regulation	6/8 capacitor, 12/6 ULTRA capacitor + AVR
Output power at power factor cos phi =1	6: 5.2 kW, 230V 50 Hz 6 ULTRA: 5,7 kW 230V 50Hz 8: 6.4 kW, 230V 50Hz 12: 10.5 kW, 230V 50Hz
Battery charger	alternator including regulator (40 Amps)

2.4 SPECIFICATION OF THE ACCESSORIES

Water scoop	3/4" = 19 mm
Inlet valve	3/4" in 19 mm out
Water strainer	19 mm in, 19 mm out
Air vent	19 mm
Inlet suction hose	19 mm
Fuel filter/water separator	30 micron
Fuel inlet and return	8 mm
Exhaust hose in/out	Ø 40 mm
Water lock	Ø 40 mm
Water/gas separator	Ø 40 mm
Anti shock mounts	Art.nr. 50230552
Foundation plate	min. 60 kg (only 6/8)
Battery charger (optional)	IVO SMART 12/10; 12V / 10 Amps, 230V/50Hz

2.5 INSTALLATION MATERIALS WHISPER 6/8/12/6 ULTRA

WATER INLET KIT 3/4" (20mm)

no	qtt	artículo	description	dimensions
1	1	50230052	Intake strainer	3/4
2	1	50230042	Lever operated ball valve FF	3/4
3	1	50221004	Male hose connection	3/4x20
3	4	50221502	Hose clamps	19-29 mm
5	3	50220056	Outboard cooling water hose	20x28 mm
6	2	50221007	Male hose connection	1/2x20
7	1	50230060	Nickel plated brass intake strainer 1/2	
8	1	50230067	Mounting bracket waterstrainer	
TOTAL		50230211	WATER INLET KIT 20 mm	

AIR VENT KIT 3/4" (20mm)

no	qtt	artículo	description	dimensions
4	4	50221502	Hose clamps	19-29 mm
5	3	50220056	Outboard cooling water hose	20x28 mm
11	2	50221031	Bend male type with hose connection	1/2x20
12	1	50221042	TEE fittings	1/2
13	1	50230001	Syphon breaker valve	1/2
14	1	50221001	Male hose connection	3/8x13
15	1	50221521	Hose clamps	12-20 mm
16	1,5	50220055	Outboard cooling water hose	12x18,2 mm
TOTAL		50230212	AIR VENT KIT 20 mm	

EXHAUST KIT 40 mm

no	qtt	artículo	description	dimensions
21	1	50221481	Hose connector	40 mm
22	5	50221506	Hose clamps	44-56 mm
23	3	50220033	Marine exhaust hose	40 mm inw
24	1	50230071	Waterlock	40 mm
25	1	50230038	Brass through hull fitting hose connection 1 1/4x40	
TOTAL		50230203	EXHAUST KIT 40 mm	

OPTIONAL INSTALLATION MATERIALS

no	qtt	artículo	description	dimensions
21A	1	50201830	Elbow 90 degr adapter exhaust hose	40 mm
22	2	50221506	Hose clamps	44-56 mm

WATER SEPERATOR KIT 40 mm

no	qtt	artículo	description	dimensions
22	4	50221506	Hose clamps	44-56 mm
23	2,5	50220033	Marine exhaust hose	40 mm inw
31	1	50221015	Male hose connection	1 1/4 x 40
32	1	50230044	Lever operated ball valve FF	1 1/4
33	1	50230033	Brass through hull fitting	1/1/4x70
34	1	50230080	Water exhaust fumes seperator	40-40-40
35	4	50201121	Vibration mounting	25x30 mm M8
36	4	50211152	Bolt	M8x16
37	4	50211465	Nut	M8
38	8	50211405	Washer	M8
39	8	50211445	Lock washer	M8
TOTAL		50230204	WATER SEPERATOR KIT	

FUEL KIT

no	qtt	artículo	description	dimensions
41	2	50221203	Straight coupling	8 mm
42	1	50230090	Fuel strainer/water separator	M14x1,5 mm
43	2	50221618	Parallel male stud coupling	M14 - 8 mm
44	2	50221644	Reducing male nipple	M14-M16 60 gr.
45	2	50221615	Hose connection	8 mm
46	2	50221616	Nut coupling	M16x1,5 mm
47	1	50221252	Nipple hose pipe	8 mm
48	4	50221522	Hose clamps	10-16 mm
49	2	50221632	Gasket ring	14x20x1,5 mm
TOTAL		50230205	FUEL KIT	

OPTIMAL INSTALLATION MATERIALS

no	qtt	artículo	description	dimensions
50	1	50222020	Copper fuel pipe	6x8 mm
51	1	50220063	Fuel hose	8x16 mm

BATTERY INSTALLATION KIT 85 Ah

no	qtt	artículo	description	dimensions
51	1	64000850	Battery	85Ah
52	1	43011030	Battery charger	
53	1	68060100	Battery terminal +	M8
54	1	68060200	Battery terminal -	M8
55	1	68456902	Isolation cap	
56	1	68456914	Isolation cap	
57	1	79009005	Battery switch	250 Amp
58	4	6503001608	Cable connectors	M8x16
58	4	6503002508	Cable connectors	M8x25
TOTAL		50230216	BATTERY INSTALLATION KIT	85 Ah

BASE PLATE KIT 6/8 (3000 rpm)

no	qtt	artículo	description	dimensions
61	4	50230552	Rubber mountings	M12
62	1	50230014	Base plate Whisper 6/8	
63	1	50230011	Fastener kit base plate	
TOTAL		50230209	BASE PLATE KIT 6/8	

RUBBER MOUNTING KIT

no	qtt	artículo	description	dimensions
64	1	50230015	Fastener kit rubber mountings	
61	4	50230552	Rubber mountings	M12
TOTAL		50230217	RUBBER MOUNTING KIT	

- Fuel kit
- Battery installation kit
- Base plate kit

Whisper 6/8/12/6 ULTRA

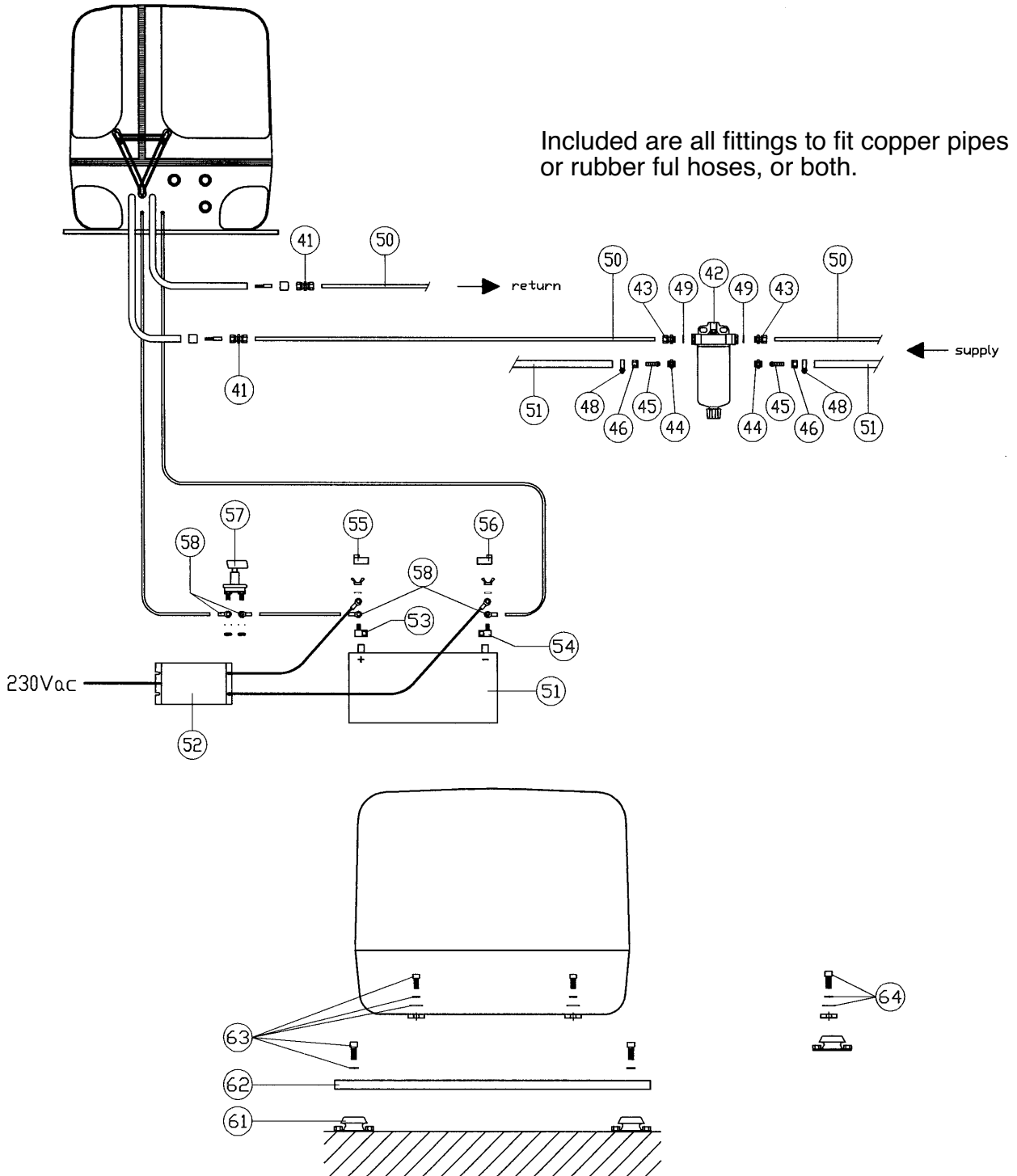

- Water inlet kit
- Air vent kit
- Exhaust kit
- Water separator kit

Whisper 6/8/12/6 ULTRA

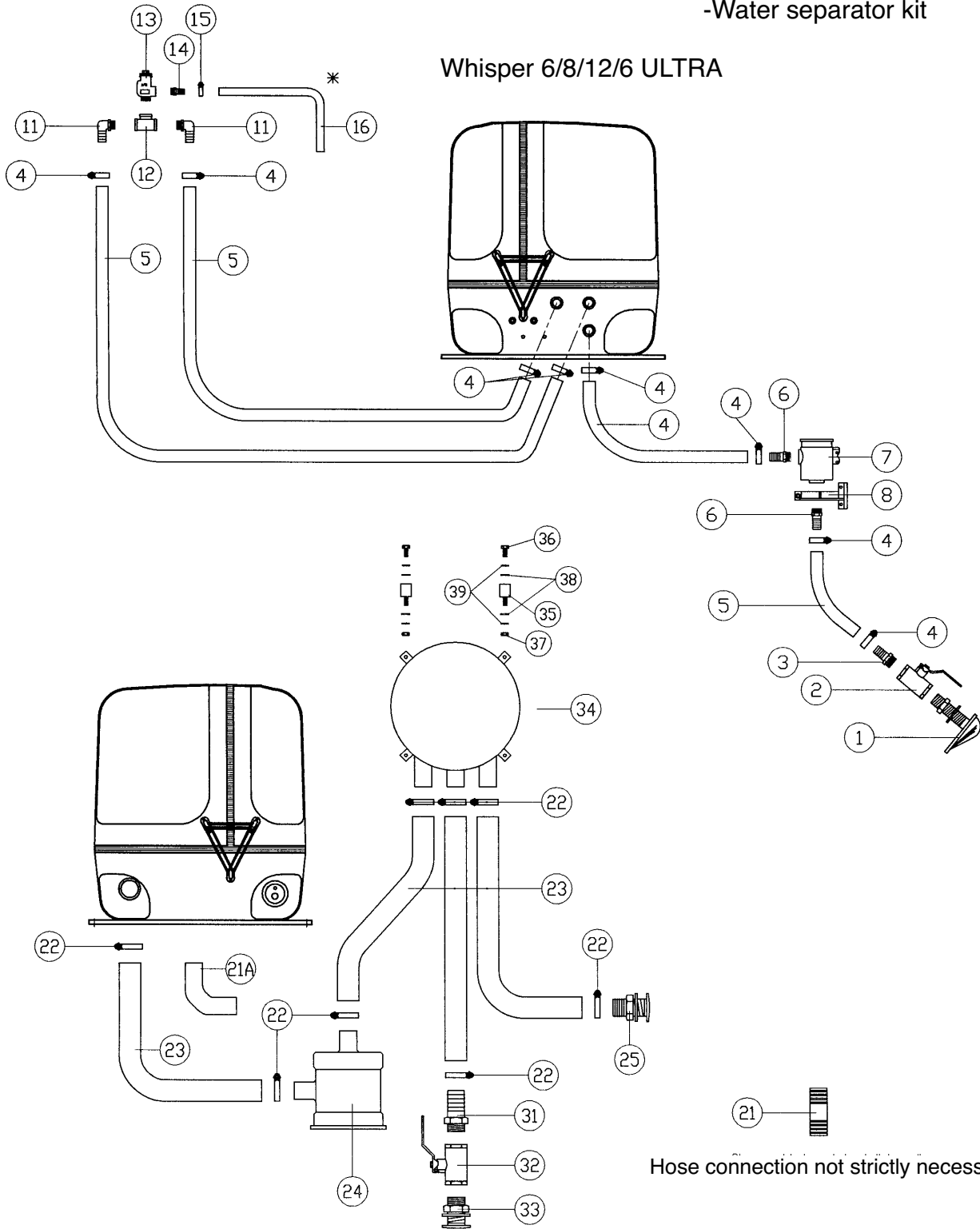

Hose drain should go downwards. Water must flow out freely. Refer to installation manual for proper installation air-vent kit. Faulty installation can cause serious damage.

3 DIAGRAMS & DRAWINGS

3.1 DC WIRING DIAGRAM

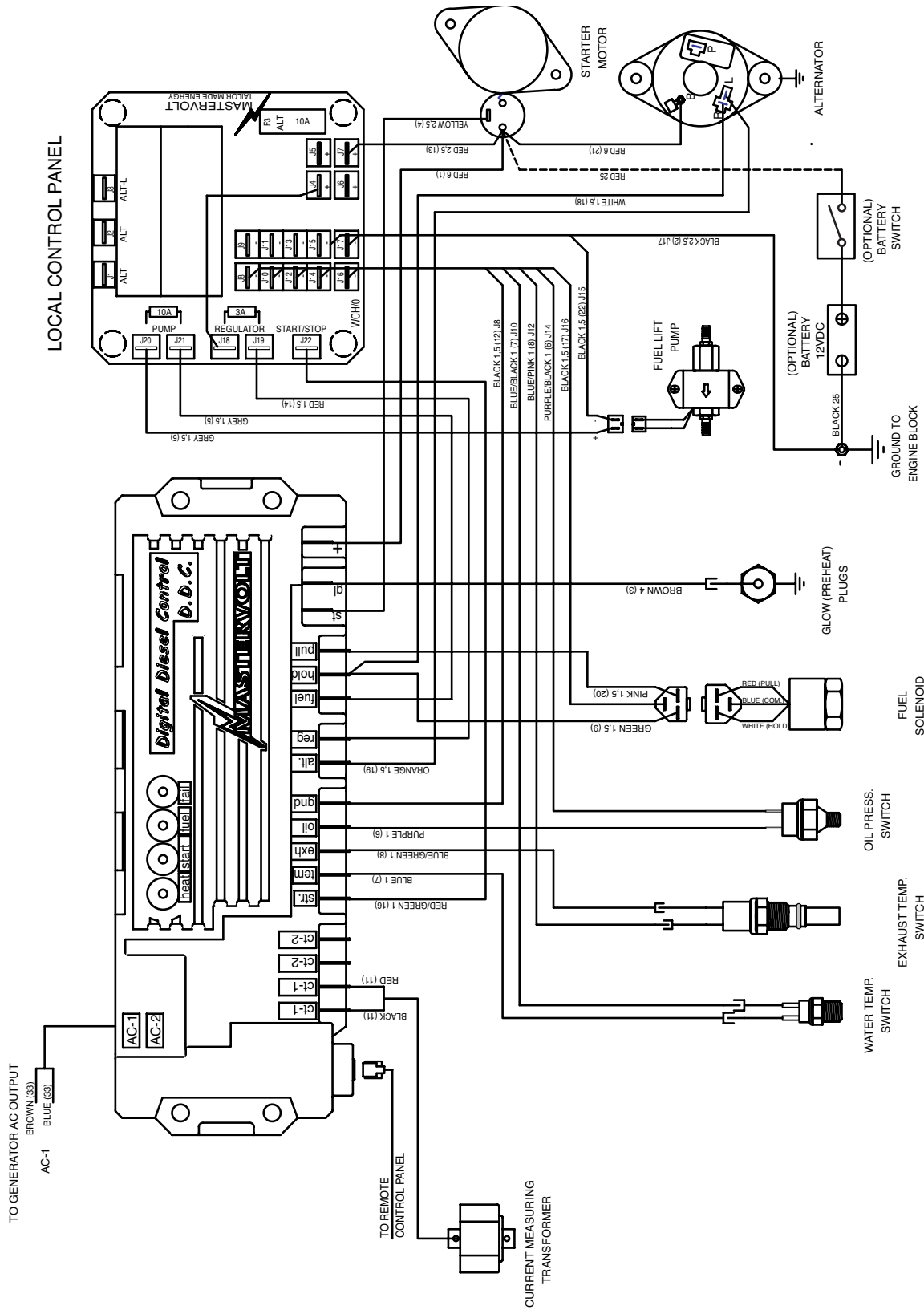

Fig. 14.

3.2 CODES AND COLORS

	Cable code number	colour	cross section
battery > starter motor		red	25 mm ²
starter motor > DCC	1	red	6 mm ²
starter motor > LCP	13	red	2,5 mm ²
battery > ground		black	25 mm ²
ground > LCP ground (GND)	2	black	2,5 mm ²
DDC > glow plugs	3	brown	4 mm ²
DDC > starter solenoid	4	yellow	2,5 mm ²
LCP > fuel lift pump +	5	brown	1,5 mm ²
LCP > fuel lift pump -	15	black	1,5 mm ²
DDC > LCD	5	grey	1,5 mm ²
DDC > oil pressure switch	6	purple	1 mm ²
LCP > oil pressure switch	6	purple/black	1 mm ²
DDC > water temperature switch	7	blue	1 mm ²
LCP > water temperature switch	7	blue/black	1 mm ²
DDC > exhaust temperature switch	8	blue/green	1 mm ²
LCP > exhaust temperature switch	8	blue/rose	1 mm ²
DCC > fuel solenoid (hold)	9	green	1,5 mm ²
DCC > fuel solenoid (pull)	20	pink	1,5 mm ²
DCC > fuel solenoid (com.)	17	black	1,5 mm ²
B+ terminal alternator > starter motor	21	red	6 mm ²
DCC > R terminal alternator	18	wit	1,5 mm ²
DCC > L terminal alternator	19	orange	1,5 mm ²
DCC > current measuring transformer	11	black	1 mm ²
DCC > current measuring transformer	11	red	1 mm ²
DCC > LCP	12	black	1,5 mm ²
DCC > LCP	14	red	1,5 mm ²
DCC > LCP	16	red/green	1,5 mm ²
DCC > generator AC output	33	brown	1 mm ²
DCC > generator AC output	33	blue	1 mm ²

DDC=Digital Diesel Control Unit

LCP=Local Control Panel

3.3 ELECTRONIC GOVERNOR (OPTIONAL)

Fig. 16.

3.4 AC WIRING DIAGRAM WHISPER 230V 50HZ

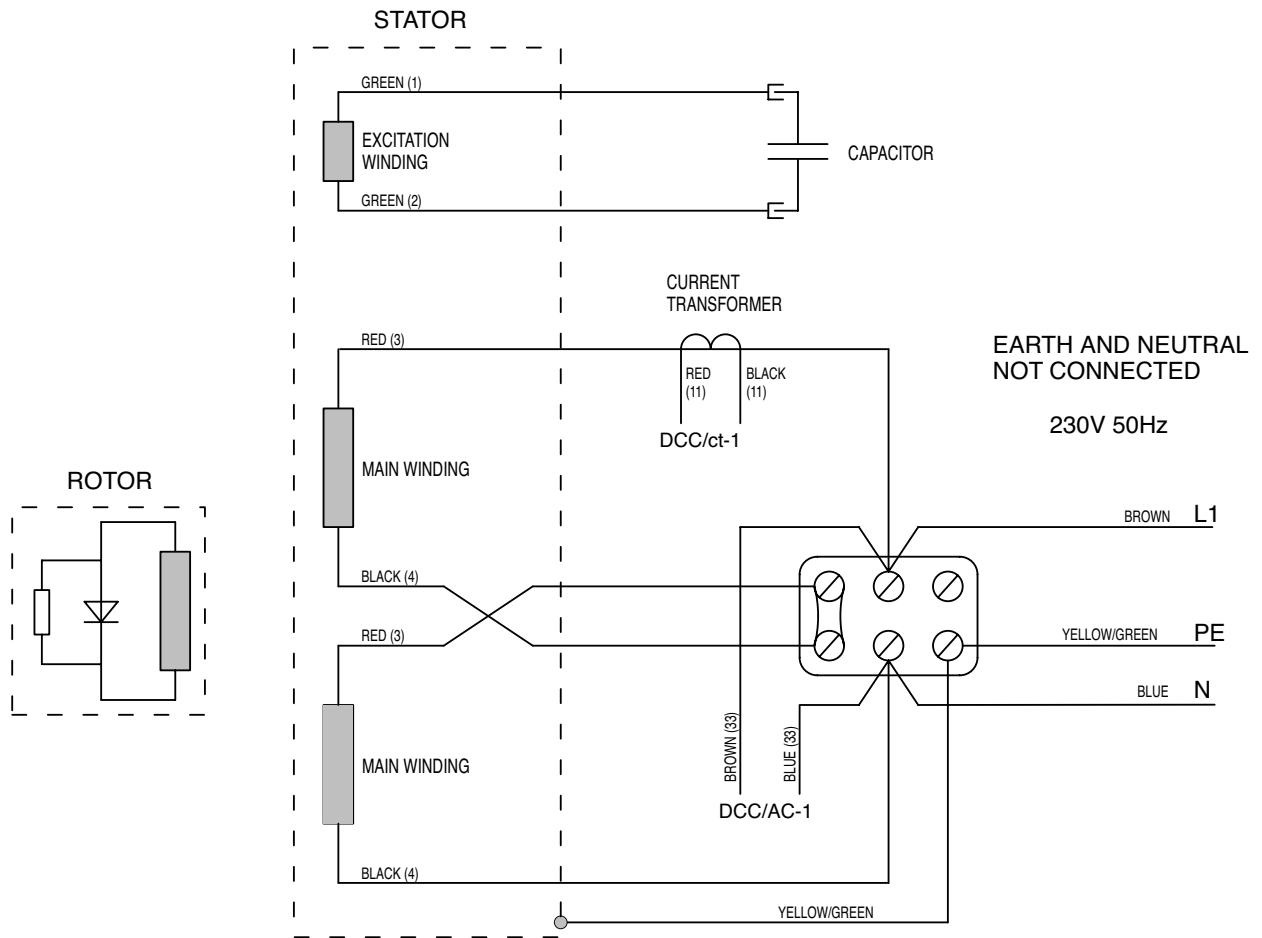

EARTH AND NEUTRAL CONNECTED

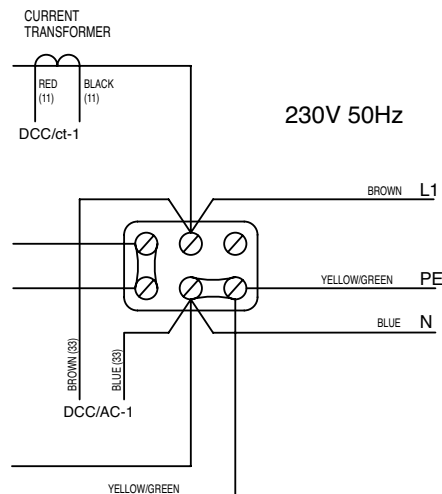

3.5 REMOTE CONTROL PANEL DRAWINGS

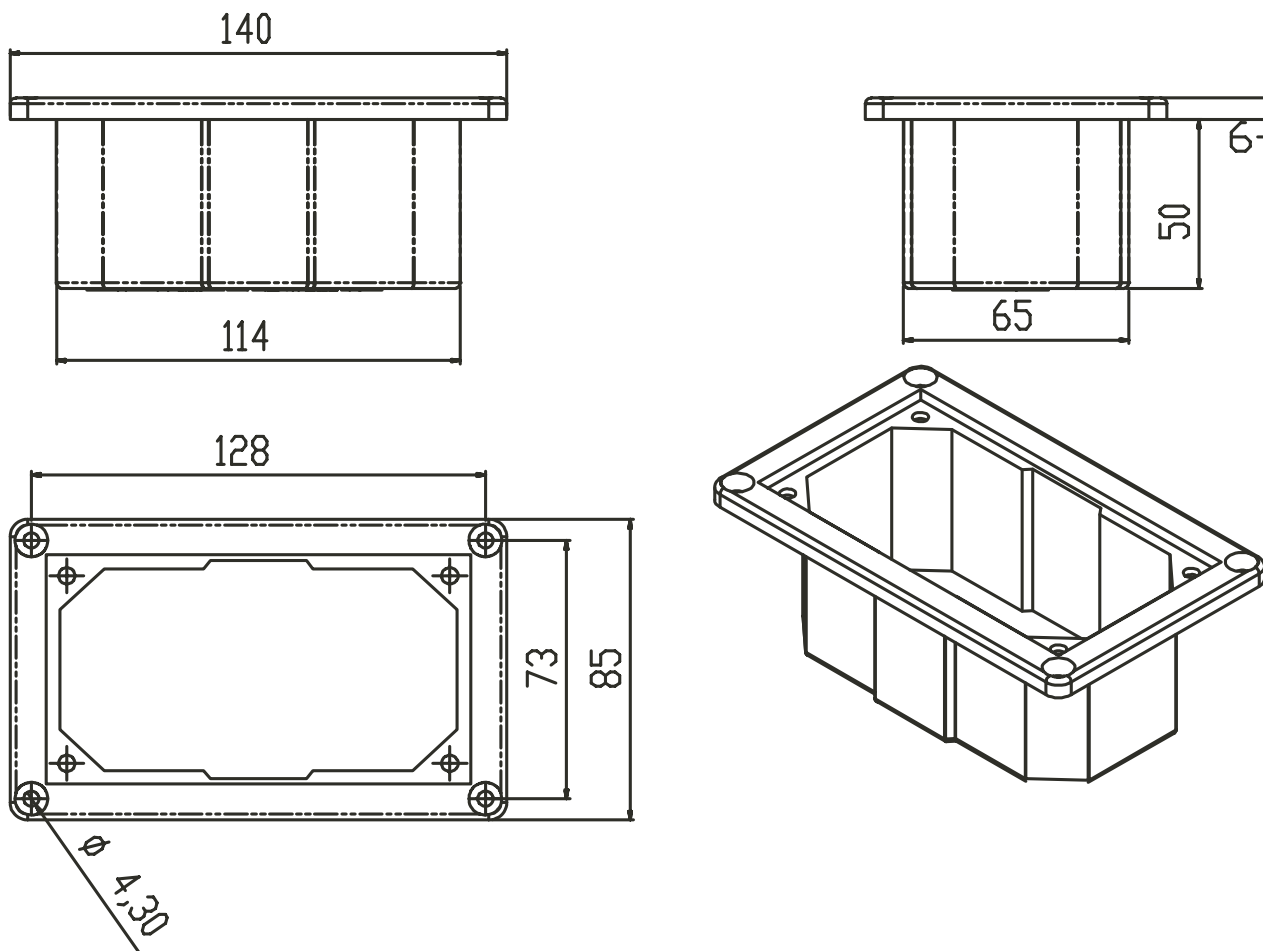

The remote panel comes in a carton that can be used as a template to drill the mounting hole.

3.6 WHISPER 6/8 DIMENSIONS

WHISPER 6/8

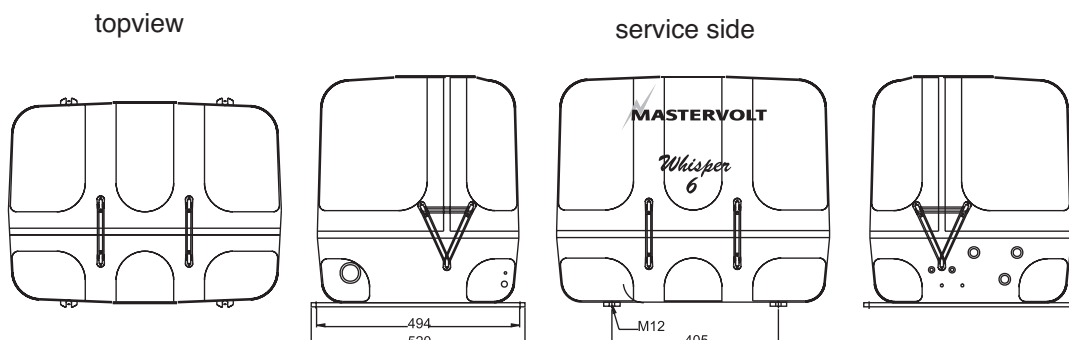

afb 18a.

WHISPER 12/6 ULTRA

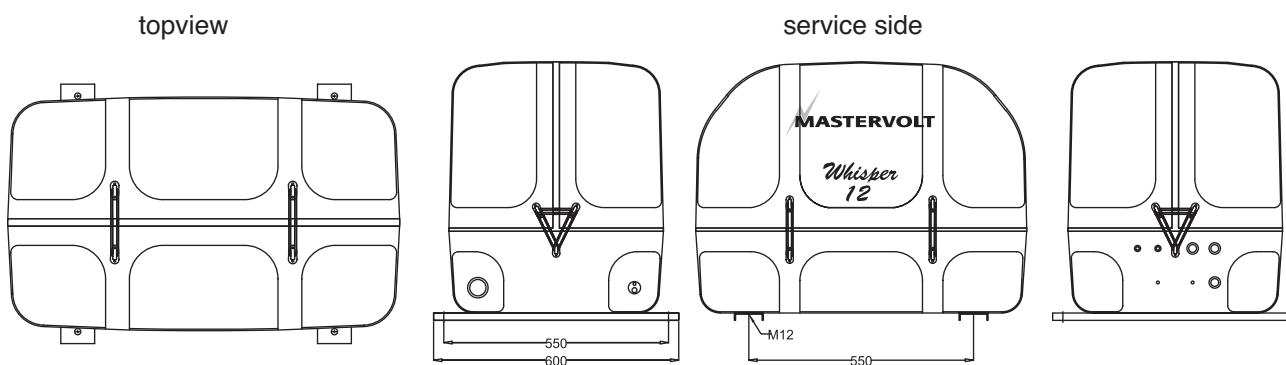

afb 18b.

CONNECTIONS WHISPER 6/8:

• exhaust:	40 mm
• fuel hose:	8 mm
• sea water in:	19 mm
• air vent connection:	19 mm
• battery +:	25 mm ²
• battery -:	25 mm ²
• remote control:	10 mtr.

POWERCABLES ISO 13297 anex A

- 6/230V 3x4 mm² (5m. included)
- 6 ULTRA 230V 3x4mm²(5m. included)
- 8/230V 3x4 mm² (5m. included)

BOX DIMENSIONS WHISPER 6/8:

• length	660 mm
• width	495 mm
• height	550 mm
• weight Whisper 6	178 kg
• weight Whisper 8	182 kg

POWERCABLES ISO 13297 anex A

- 12/230V 3x10 mm² (not included)

REMOTE CONTROL:

- 15 meter 8 wire communication cable (included)

BOX DIMENSIONS WHISPER 12/6 ULTRA

• length	810 mm
• width	525 mm
• height	615 mm
• weight Whisper 12	210 kg
• weight Whisper 6 ULTRA	225 kg



MASTERVOLT

Snijdersbergweg 93, 1105 AN Amsterdam, The Netherlands

Tel.: +31-20-3422100 / Fax: +31-20-6971006

www.mastervolt.com / info@mastervolt.com